



MVHR ECO RANGE

**Mechanical Ventilation
with Heat Recovery** for all
Residential Applications



Welcome

PROUD TO BUILD BRITISH

We've been pioneers in new air technology since 1966. Our heritage is in the design and manufacture of fans and ventilation systems. We put our energy into efficient ventilation, so you don't waste yours.

06 **MRXBOXAB-ECO2B**
Wall mounted unit with 100% bypass and integral humidistat.

14 **MRXBOXAB-ECO2B-AE**
Wall mounted unit with 100% bypass and integral humidistat.

20 **MRXBOXAB-ECO2B-1Z**
Wall mounted unit with 100% bypass and integral humidistat.

26 **MRXBOXAB-ECO3B**
Wall mounted unit with 100% bypass and integral humidistat.

34 **MRXBOXAB-ECO3B-AE**
Wall mounted unit with 100% bypass and integral humidistat.

40 **MRXBOXAB-ECO3B-1Z**
Wall mounted unit with 100% bypass and integral humidistat.

46 **MRXBOXAB-ECO4**
Wall mounted unit with 100% bypass and integral humidistat.

54 **MRXBOXAB-ECO4-AE**
Wall mounted unit with 100% bypass and integral humidistat.

60 **MRXBOXAB-ECO4-1Z**
Wall mounted unit with 100% bypass and integral humidistat.

66 **MRXBOXAB-ECO5**
Wall mounted unit with 100% bypass and integral humidistat.

74 **MRXBOXAB-ECO5-AE**
Wall mounted unit with 100% bypass and integral humidistat.

80 **MRXBOXAB-ECO5-1Z**
Wall mounted unit with 100% bypass and integral humidistat.

86 **MRXBOX95AB-WM1**
Wall mounted unit with 100% bypass and integral humidistat.

92 **MRXBOXAB-ECO-LP2**
Low profile multi-room supply and extract heat recovery with automatic Summer bypass.



All Round MVHR Solution

Nuaire's MVHR systems are a year-round ventilation solution that create a healthier living environment. The MVHR systems combine supply and extract ventilation in one balanced system with high efficiency and heat recovery, recovering up to 95% heat from your home.



All You Need in One

MVHR is fast becoming the most common method of whole home ventilation for new build properties. The system works by combining supply and extract in one unit.



Heat Exchanger

Moisture-laden, stale air is extracted from 'wet' areas, such as kitchens and bathrooms. The heat from this stale air is recovered via a heat exchanger, and this tempered air delivered into the living areas of the home.



The Most Effective Range

Nuaire's MVHR range recovers heat up to 95% efficiency, making it an effective range of MVHR units.



The Eco Range

In warmer months when cooling is required to maintain comfort levels, Nuaire's MVHR Eco range offers 100% bypass with no loss of duty.



The Full Service

What's more, MVHR systems provide continuous trickle ventilation to ensure a consistent level of fresh filtered air into the property to maintain adequate indoor air quality.

Overview

OUR MVHR SOLUTIONS



SAP identifier	MRXBOXAB-ECO2B	MRXBOXAB-ECO2B-AE	MRXBOXAB-ECO2B-1Z	MRXBOXAB-ECO3B	MRXBOXAB-ECO3B-AE	MRXBOXAB-ECO3B-1Z	MRXBOXAB-ECO4	MRXBOXAB-ECO4-AE	MRXBOXAB-ECO4-1Z	MRXBOXAB-ECO5	MRXBOXAB-ECO5-AE	MRXBOXAB-ECO5-1Z	MRXBOX95-AB-WM1	MRXBOXAB-ECO-LP2
Page no.	6	14	20	26	34	40	46	54	60	66	74	80	86	92
Size (WxHxDmm)	607x507x356	706x604x448	706x1051x448	658x623x434	754x719x525	754x1166x525	707x710x577	788x816x672	789x1453x672	658x623x434	754x719x525	754x1166x525	603x468x288	707x202x900
Weight	20kg	45kg	58kg	24kg	56kg	76kg	44kg	80kg	115kg	25kg	56kg	76kg	16KG	37kg
Filters	ISO Coarse	ISO Coarse	ISO Coarse	ISO Coarse	ISO Coarse	ISO Coarse	ISO Coarse	ISO Coarse	ISO Coarse	ISO Coarse	ISO Coarse	ISO Coarse	ISO Coarse	ISO Coarse
100% Bypass	Yes	Yes	Yes	Yes	Yes	Yes	Yes	Yes	Yes	Yes	Yes	Yes	Yes	Yes
Maximum floor area(m ²)	150	150	150	185	185	185	250	250	250	250	250	250	85	150
Maximum no of wetrooms PCDB	Kitchen + 3	Kitchen + 3	Kitchen + 3	Kitchen + 5	Kitchen + 5	Kitchen + 5	Kitchen + 5	Kitchen + 5	Kitchen + 5	Kitchen + 5	Kitchen + 5	Kitchen + 5	Kitchen + 1	Kitchen + 3
Specific fan power (PCDB down to)	0.55	0.55	0.55	0.56	0.56	0.56	0.62	0.62	0.62	0.63	0.63	0.63	0.91	0.48
Heat Recovery % (PCDB up to)	90%	90%	90%	90%	90%	90%	94%	94%	94%	90%	90%	90%	86%	78%
Spigot Size	125mm dia	125mm dia	125mm dia	150mm dia	150mm dia	150mm dia	200mm dia	200mm dia	200mm dia	150mm dia	150mm dia	150mm dia	125mm dia	204x60mm dia
Opposite Handed unit code	MRXBOXAB-ECO2B-OH	MRXBOXAB-ECO2B-AE-OH	MRXBOXAB-ECO2B-1Z-OH	MRXBOXAB-ECO3B-OH	MRXBOXAB-ECO3B-AE-OH	MRXBOXAB-ECO3B-1Z-OH	MRXBOXAB-ECO4-OH	MRXBOXAB-ECO4-AE-OH	MRXBOXAB-ECO4-1Z-OH	MRXBOXAB-ECO5-OH	MRXBOXAB-ECO5-AE-OH	MRXBOXAB-ECO5-1Z-OH	MRXBOX95-AB-WM1-OH	MRXBOXAB-ECO-LP2-OH

ALL ROUND MVHR SOLUTIONS

MRXBOXAB-ECO2B

The MRXBOXAB-ECO2B is a wall mounted MVHR unit with 100% automatic bypass and integral humidistat as listed on the SAP Product Characteristics Database (PCDB).

Owing to its intelligent and smart design, there will be no reduction in airflow when operating in bypass mode, resulting in balanced performance. The unit is designed to provide optimised balanced (supply and extract) mechanical ventilation with heat recovery.

The two airflows pass through the heat exchanger, where up to 95% of the heat from the extract air is transferred into the supply air before supplying into the habitable rooms, creating comfortable and well-ventilated homes. The two independent fans have infinitely variable speed control for background and boost ventilation rates.

The ECO2B has a Summer Bypass function which automatically activates in warmer months, to ensure the property is well-ventilated and comfort levels are

maintained in the home by continuously drawing in fresh filtered air into the habitable rooms. The unit is compact enough to go into a cupboard space, as well as being powerful enough to ventilate the kitchen and up to 3 wet rooms.

Units are available as SW versions with a third controllable speed for Approved Document F&O purge rates and additional SW switch to select between seasonal bypass logic profiles.

Opposite Handed (OH) configuration available.



Installation Features:



Achieves
100%
duty in bypass
mode

Performance

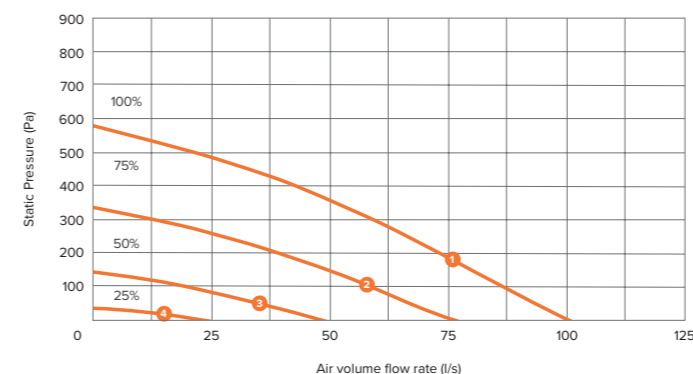

MRXBOXAB-ECO2B

Wall mounted unit with 100% bypass and integral humidistat.

MRXBOXAB-ECO2B-OH

Opposite Handed configuration wall mounted unit with 100% bypass and integral humidistat.

SUMMER/WINTER SWITCH ONLY (SW)

Units are available as SW versions with a third controllable speed and a Summer/Winter switch, allowing selection of seasonal bypass logic profiles.

Electrical & Sound

ECO2B Sound Data											
Curve	Maximum power consumption (Watts)		Sound Power Levels dB re 1pW (Frequency Hz)							dBa @3m	
			63	125	250	500	1k	2k	4k		8k
1	152	Open inlet	47	52	60	59	50	47	34	29	
		Open outlet	58	66	69	71	69	67	58	49	
		Breakout	62	60	59	61	51	48	36	27	42
2	67	Open inlet	43	45	58	52	45	41	27	19	
		Open outlet	55	62	63	67	62	60	51	41	
		Breakout	52	57	53	54	45	41	29	18	35
3	20	Open inlet	40	39	49	43	36	30	<16	<16	
		Open outlet	47	53	54	57	52	49	38	25	
		Breakout	42	48	45	45	36	31	<16	<16	26
4	7	Open inlet	38	33	32	29	20	<16	<16	<16	
		Open outlet	38	36	36	38	31	22	<16	<16	
		Breakout	37	34	29	27	17	<16	<16	<16	<16

The maximum power consumption shown above (Watts) is consumed on units running continuously, not taking into account any heat recovery saving and based on SAP Product Characteristic Database (PCDB) testing. The breakout case-radiated dBA values are given for Hemispherical free field radiation at 3m - to obtain the Spherical radiated data, subtract 3 dBA.

Please note: Sound data is provided at a particular duty point for 25%, 50%, 75% and 100%. For accurate sound data at a specific speed duty please use Nuaire's fan selector or call the office on 029 2085 8500.

SAP/PCDB Data

Product Code	MRXBOXAB-ECO2B		
SAP Identifier	MRXBOXAB-ECO2B		
Application	Specific Fan Power (W/l/s)	Heat Exchange Efficiency	Energy Saving Trust Best Practice Compliant
Kitchen + 1 Wet Room	0.55	90%	Yes
Kitchen + 2 Wet Rooms	0.65	89%	Yes
Kitchen + 3 Wet Rooms	0.8	87%	Yes
Kitchen + 4 Wet Rooms	1.01	86%	Yes

Filters

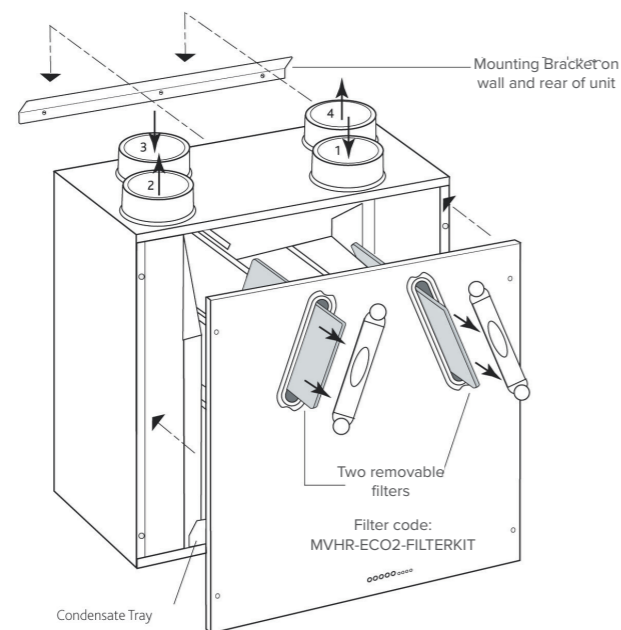

Handing Information

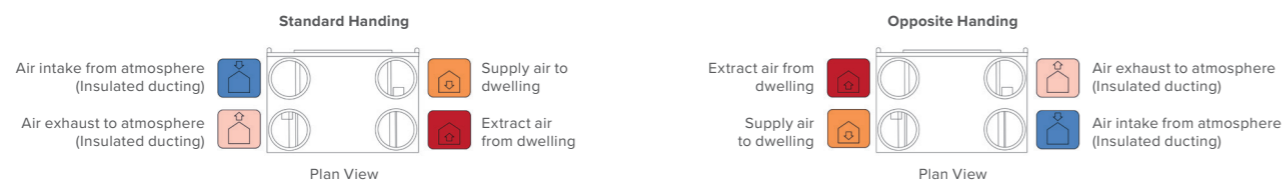

Technical – MRXBOXAB-ECO2B

Dimensions (mm) – Standard Unit Configuration

Weight - 20kg

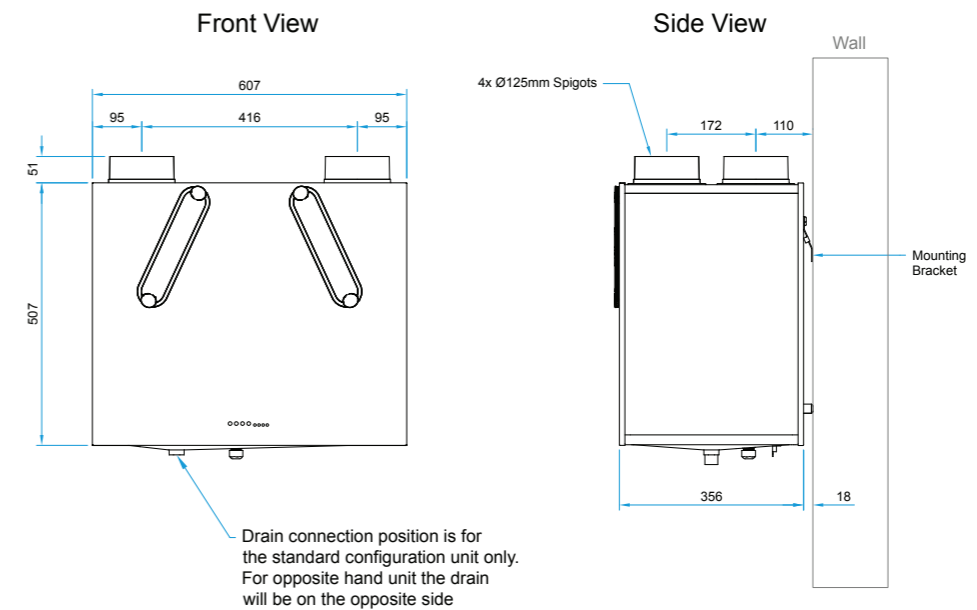

Standard Model

Detail of unit control on front panel.

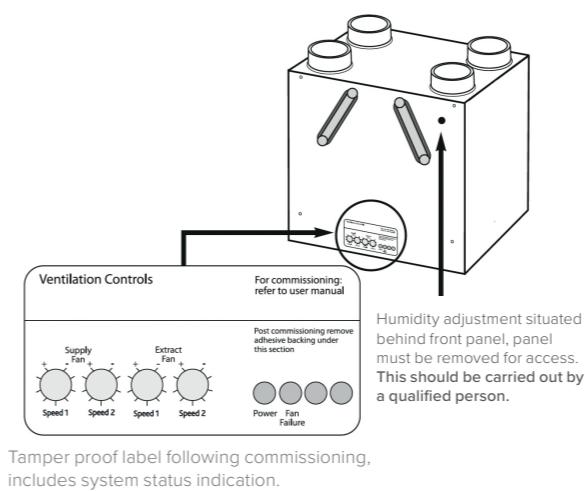

SW Model

Unit Control On Front Panel (Standard Configuration Only)

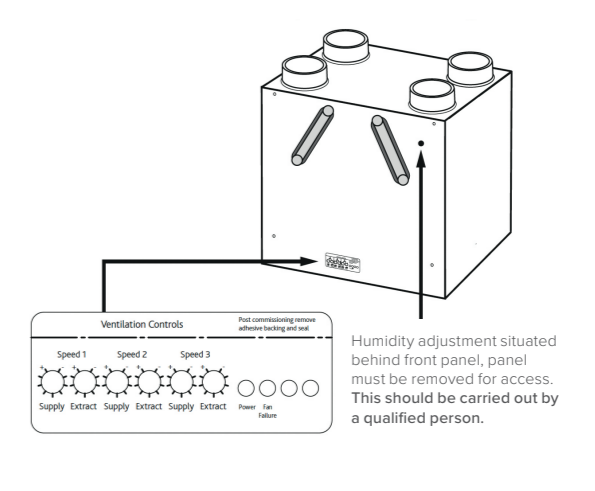

Wiring – MRXBOXAB-ECO2B

Unit Serving Kitchen & Bathroom

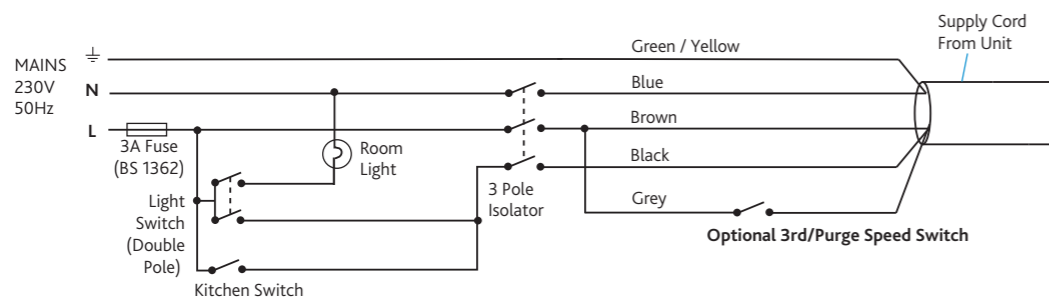

Unit Serving Kitchen & Two Bathrooms

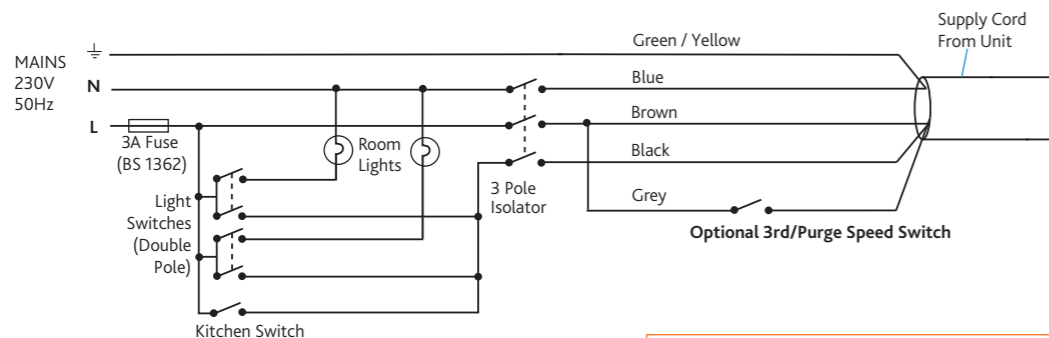

Summer/Winter Switch



Volt free Summer / Winter Switch (supplied with unit)
Polarity is inconsequential
Warning! - Do not connect to mains!

Electrical Details

Please note: the electrical connection of the unit must be carried out by a qualified electrician.

The unit is supplied with a flexible cord for connection to the mains supply. NOTE: This unit must be earthed.

The mains power supply cable should be connected to a fixed wiring installation, via a fused isolator, in accordance with current IEE wiring regulations.

Specification

MRXBOXAB-ECO2B

SPECIFICATION

The unit shall be fully insulated providing excellent thermal and acoustic characteristics and shall be complete with a multiplate, counter-flow, high-efficiency heat exchanger block, with a thermal efficiency of up to 95%. The heat exchanger shall be protected by ISO Coarse filters on fresh air inlet and system extract. The heat exchanger and filters shall be accessible via the front access panel, enabling quick and easy maintenance.

The unit shall have low energy, high-efficiency EC fan/motor assemblies with sealed for life bearings, the impellers shall be backward-curved centrifugal type. The motors shall be suitable for an ambient temperature of 40°C.

The unit shall be supplied complete with an insulated condensate drip tray and 21.5mm drain connection. The unit shall be suitable for 125mm circular ducting. Note: The unit is also available in Opposite Handed format, refer to spigot configuration for set up.

The breakout noise level and power requirements shall be as detailed by the unit manufacturer and in accordance with the ventilation equipment schedule. Units shall be MRXBOXAB-ECO2B as manufactured by Nuaire and shall be listed on the SAP PCDB. MRXBOXAB-ECO2B-OH are Opposite Handed assemblies compliant as per standard handed versions listed in SAP PCDB.

OPERATION FOR TWO SPEED (STANDARD MODEL)

The supply and extract system shall be positioned as indicated on the drawings and shall be in accordance with the particular fan schedule in the specification.

The combined supply and extract with heat recovery unit shall supply filtered fresh air to each of the habitable rooms and moisture-laden air shall be extracted from all wet areas, e.g. bathroom, en suite, w.c, kitchen, utility rooms etc. The supply air shall be pre-heated by the warm extract air via the integrated counter-flow heat exchanger element. The extracted air shall also be filtered before it reaches the heat exchanger block.

The ventilation unit shall vary its speed and, therefore, the ventilation rate, as it receives signals from one of the following:

- Switched live signal from light/remote switches/remote switch/humidistat switch.

When signals are received, the fan shall alter its speed to adjustable, normal and boost rates. The unit shall have the facility to commission the supply and extract fans independently on minimum speed (continuous background ventilation) and boost speed via inbuilt minimum and maximum speed adjustment. The fans shall have infinitely variable speed control.

INTEGRAL AUTOMATIC HX BYPASS WITH NO REDUCTION IN AIRFLOW

The bypass damper shall open automatically via a wax actuator, allowing the air to bypass the heat exchanger to deliver fresh filtered air during the warmer months.

The automatic bypass diverts 100% airflow around the heat exchanger with no reduction in airflow as independently tested by the BRE.

INTEGRAL HUMIDITY SENSOR

The integral humidity sensor incorporated within the extract fan chamber will automatically boost both the extract and supply fan, to the commissioned boost speed, when the humidity level exceeds that set by the front panel mounted adjustment potentiometer.

SUMMER/WINTER (SW) SWITCH THIRD SPEED

The unit shall feature volt-free connections for a positional switch controlling the bypass logic profile. Summer setting shall target under 20 degrees C internal dwelling temperature. Winter setting shall ensure heat recovery at all times. Temperature control logic shall be factory pre-set and require no on-site programming. The unit shall feature 3 commissionable speeds for both supply and extract. It shall be possible to enable the unit to its 3rd speed by means of a switch or a programmable thermostat with occupant override CM-THERM-CONTROL. The 3rd speed (overheating) shall be inhibited when outside air temperature exceeds inside temperature and bypass closes so that extracted air cools incoming fresh air.

CONTROL OPTIONS

All versions are built in functions integrally mounted within the fan unit on a purpose made PCB, all such components are pre-wired and factory fitted by the manufacturer:

- Independent control of background supply and extract flow rates.
- Independent control of boost speed supply and extract flow rates.
- Integral heat exchanger frost protection.
- Integral S/L terminal for boost from remote switch, e.g. light switch.
- Additional S/L terminal for 100% boost speed from remote switch, e.g. plate switch.
- Discreet daily run monitor.
- SL521- If using more than one sensor or switch, a multi switch live controller may be required.
- Indication and controls – The unit shall have clear LED visual indication for maintenance, servicing and operation mode, i.e. HX bypass, frost protection.

The unit comes with 2 years warranty (including parts and labour).

ACOUSTIC SOLUTIONS

MRXBOXAB-ECO2B

Nuaire's First Fix and Acoustic Solutions are designed to not only reduce noise but to improve the installation when wall or cupboard mounting the MRXBOXAB-ECO2B unit.

Offering the only complete MVHR acoustic and first fix solution to overcome both noise and ease of installation. The acoustic solution addresses ducting noise and is an aesthetically pleasing design for cupboard installation.

Opposite Handed (OH) units available.

- Section 1** - First fix plenum chamber
- Section 2** - Silencer box has four airflow chambers, reducing induct noise
- Section 3** - MVHR unit

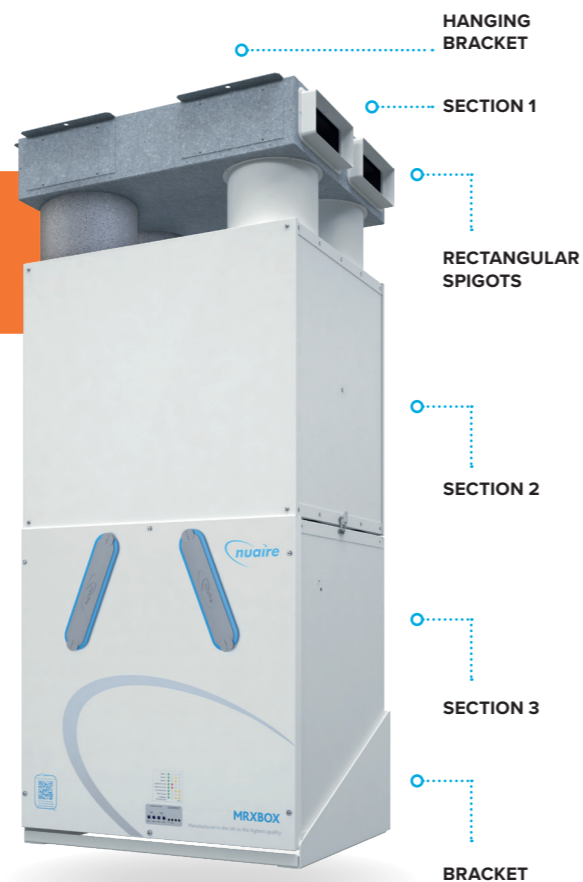

Installation Features:

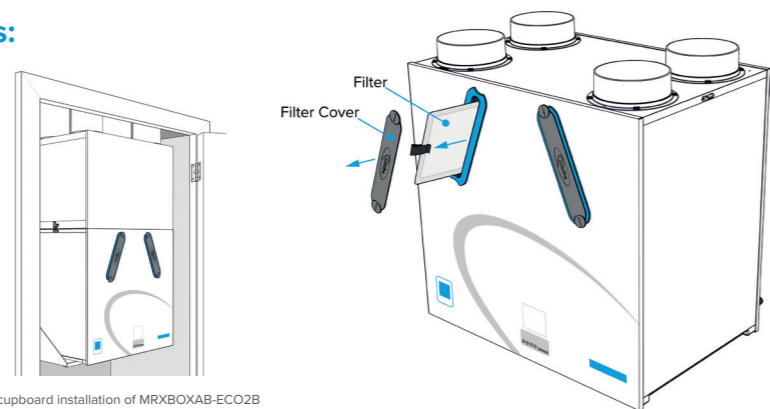

Typical cupboard installation of MRXBOXAB-ECO2B

Acoustic data for MRXBOXAB-ECO2B with Silencer and/or First Fix box

Ancillary Sound Data								
MRXBOX-SIL2	63	125	250	500	1K	2K	4K	8K
SUPPLY/DISCHARGE	-11	-10	-9	-14	-23	-26	-20	-15
INTAKE/EXTRACT	-8	-10	-9	-10	-22	-24	-16	-13
MRXBOX-FF2								
SUPPLY/DISCHARGE	-8	-5	-4	-7	-7	-7	-6	-6
INTAKE/EXTRACT	-4	-7	-5	-6	-7	-7	-6	-4
MRXBOX-SIL2+ FF2								
SUPPLY/DISCHARGE	-18	-18	-18	-25	-30	-35	-28	-26
INTAKE/EXTRACT	-12	-20	-15	-16	-22	-24	-19	-16

Technical – MRXBOXAB-ECO2B

Dimensions (mm)

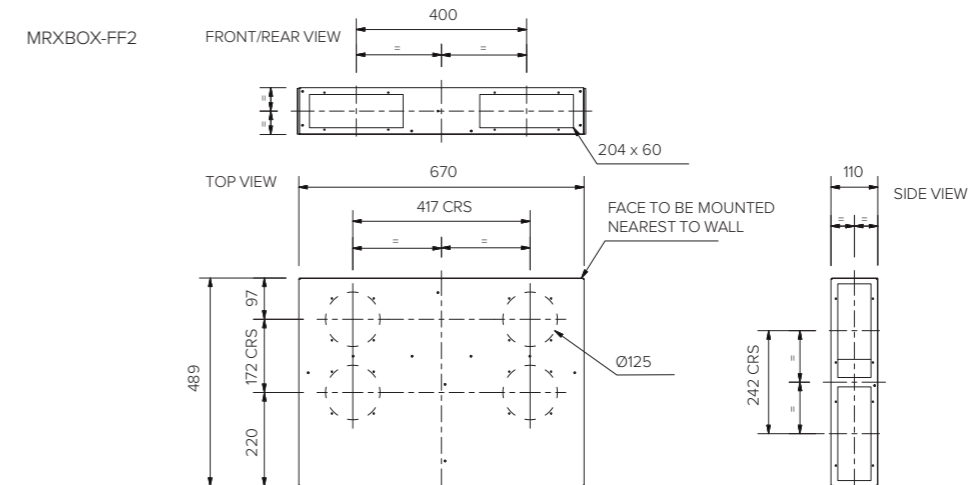
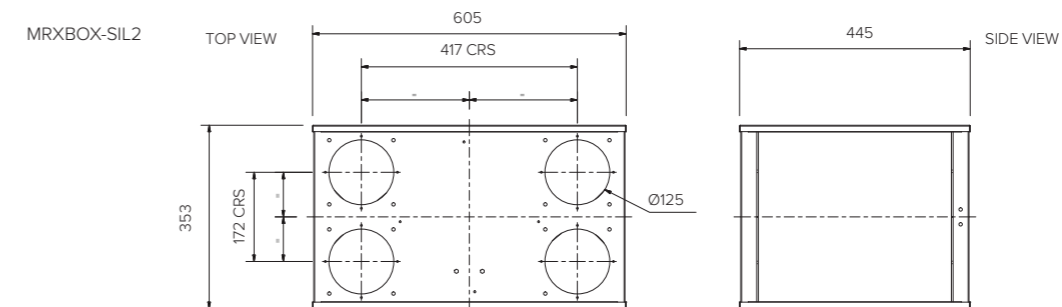

COMPLETED SYSTEM

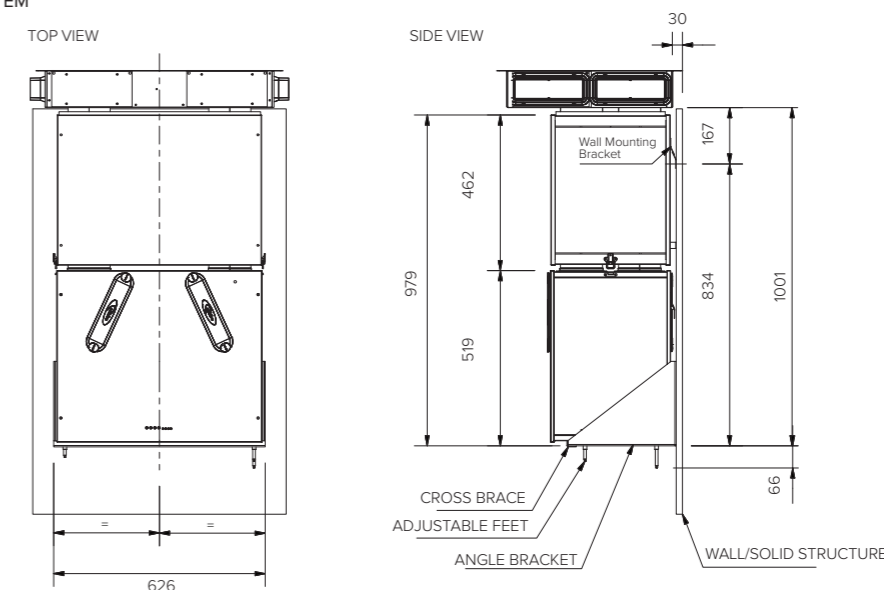

ACOUSTIC ENCLOSURE

MRXBOXAB-ECO2B-AE

The AE is a wall mounted MVHR unit with a factory fitted acoustic enclosure. Flexible duct connections and anti-vibration mounts are incorporated within the AE providing vibration isolation from the supporting structure and significantly reducing case radiated noise, even at high running speeds.



The unit is equipped to commission the supply and extract fans independently on both minimum and maximum speeds, with the heat exchange blocks being able to recover up to 95% of the wasted heat that has been extracted from the 'wet areas' within the property and at the same time drawing in fresh supply air from outside.

Units are available as SW versions with a third controllable speed for Approved Document F&O purge rates and additional SW switch to select between seasonal bypass logic profiles.

Opposite Handed (OH) configuration available.

The two independent fans have infinitely variable speed control for background and boost ventilation rates. Nuaire guarantee that 100% design airflow rate is maintained in bypass operation.



Installation Features:



Performance

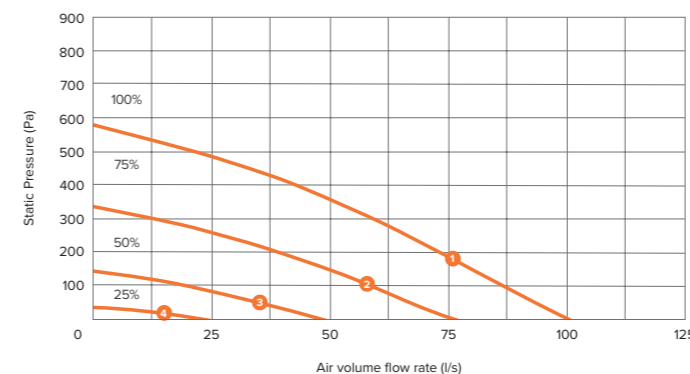

MRXBOXAB-ECO2B-AE

Wall mounted unit with 100% bypass and integral humidistat.

MRXBOXAB-ECO2B-AE-OH

Opposite Handed configuration wall mounted unit with 100% bypass and integral humidistat.

SUMMER/WINTER SWITCH ONLY (SW)

Units are available as SW versions with a third controllable speed and a Summer/Winter switch, allowing selection of seasonal bypass logic profiles.

Electrical & Sound

ECO2B-AE Sound Data											
Curve	Power consumption (Watts)		Sound Power Levels dB re 1pW (Frequency Hz)								dBA @3m
			63	125	250	500	1k	2k	4k	8k	
1	152	Open inlet	47	53	61	57	51	48	33	30	
		Open outlet	59	67	70	70	67	68	57	49	
		Breakout	57	59	49	44	28	18	<16	<16	29
2	67	Open inlet	43	45	58	52	45	41	27	19	
		Open outlet	55	62	63	67	62	60	51	41	
		Breakout	47	55	45	39	21	<16	<16	<16	24
3	20	Open inlet	40	39	49	43	36	30	<16	<16	
		Open outlet	47	53	54	57	52	49	38	25	
		Breakout	37	46	37	30	<16	<16	<16	<16	<16
4	7	Open inlet	38	33	32	29	20	<16	<16	<16	
		Open outlet	38	36	36	38	31	22	<16	<16	
		Breakout	35	32	24	17	<16	<16	<16	<16	<16

The maximum power consumption shown above (Watts) is consumed on units running continuously, not taking into account any heat recovery saving and based on SAP Product Characteristics Database (PCDB) testing. The breakout case-radiated dBA values are given for Hemispherical free field radiation at 3m – to obtain the Spherical radiated data, subtract 3 dBA.

Please note: Sound data is provided at a particular duty point for 25%, 50%, 75% and 100%. For accurate sound data at a specific speed duty please use Nuaire's fan selector or call the office on 029 2085 8500.

SAP/PCDB Data

Product Code	MRXBOXAB-ECO2B-AE		
SAP Identifier	MRXBOXAB-ECO2B		
Application	Specific Fan Power (W/l/s)	Heat Exchange Efficiency	Energy Saving Trust Best Practice Compliant
Kitchen + 1 Wet Room	0.55	90%	Yes
Kitchen + 2 Wet Rooms	0.65	89%	Yes
Kitchen + 3 Wet Rooms	0.8	87%	Yes
Kitchen + 4 Wet Rooms	1.01	86%	Yes

Standard Model

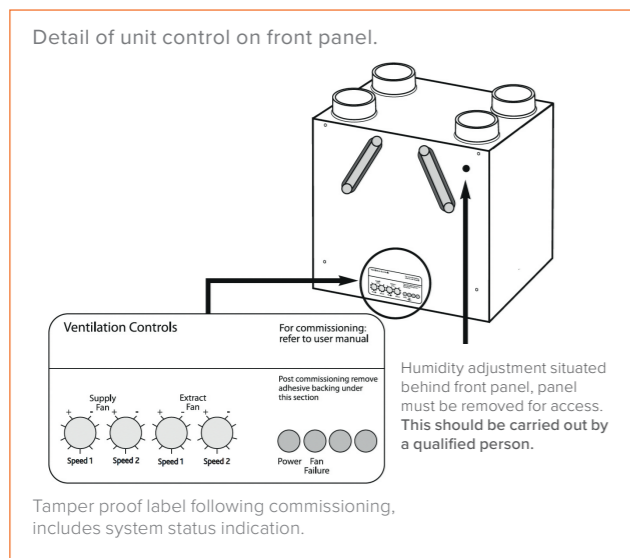

SW Model

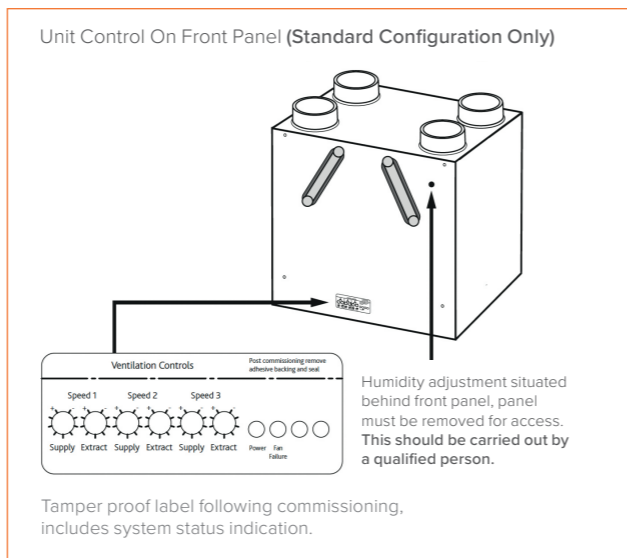

Handing Information

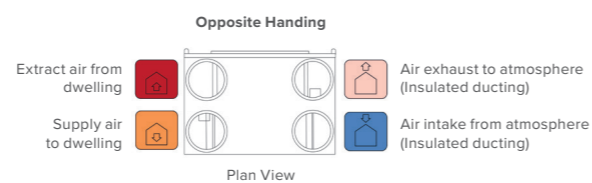
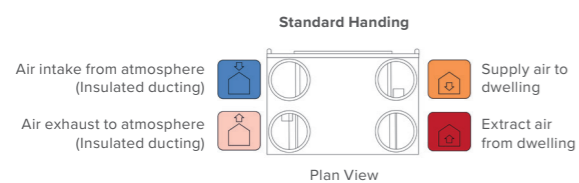

Technical – MRXBOXAB-ECO2B-AE

Dimensions (mm) – Standard Unit Configuration

Weight - 45kg

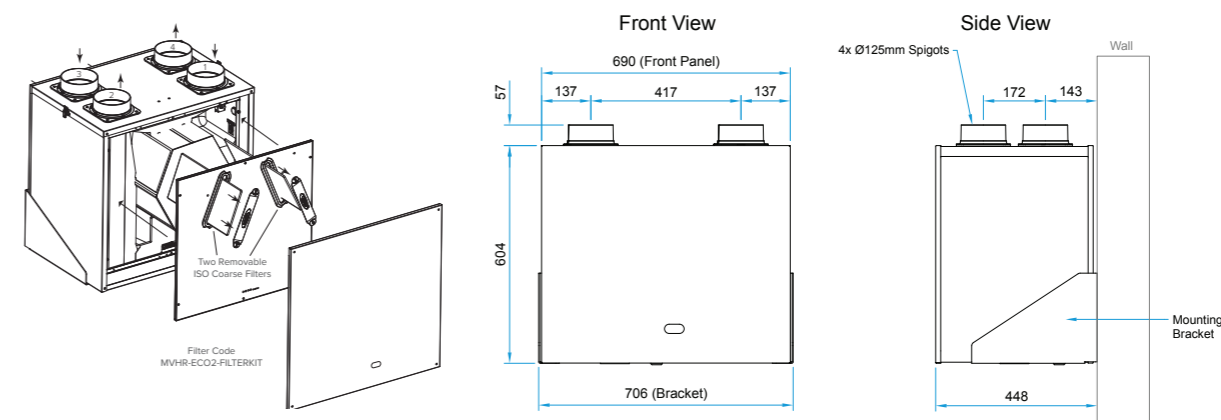

Ancillaries

MRXBOXAB-ECO2B-AE

The MRXBOX-DB2 is fitted on top of the MRXBOXAB-ECO2B-AE before installation and offers a neat arrangement by directly distributing the initial ducting. It further benefits this MVHR system by reducing any in-line noise breakout, therefore, improving this acoustic solution.

Dimensions (mm)

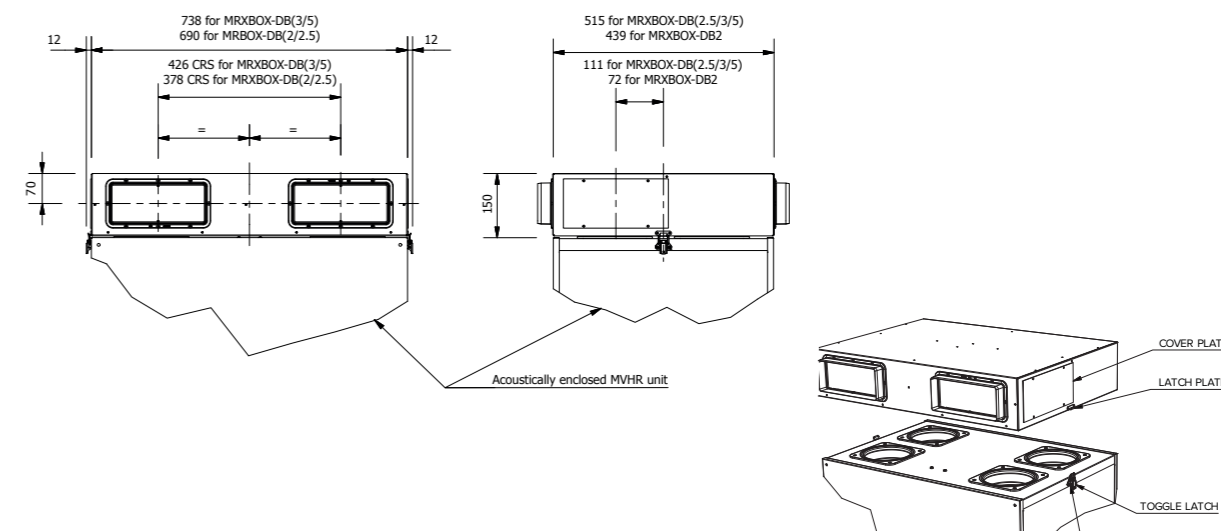

MRXBOX-ECO2B-AE

Unit Serving Kitchen & Bathroom

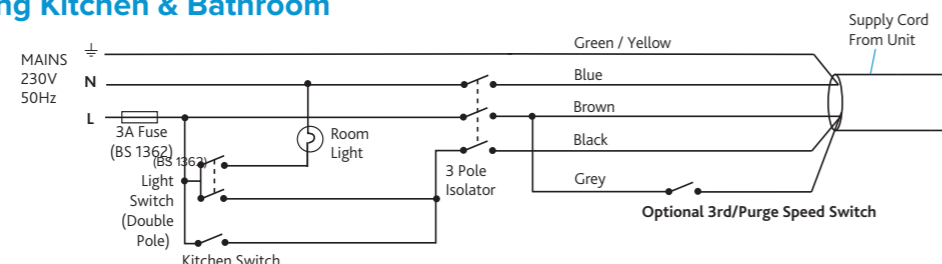

Unit Serving Kitchen & Two Bathrooms

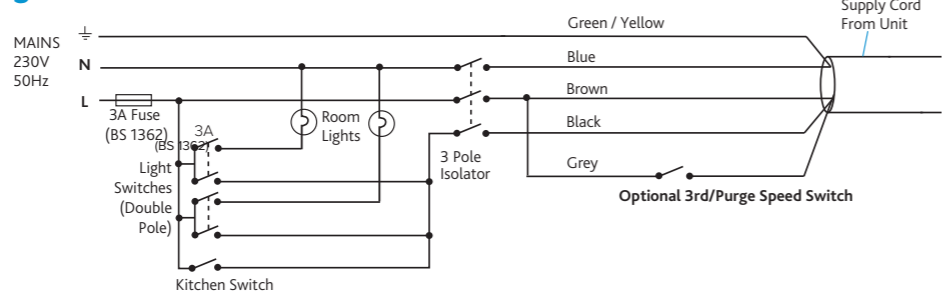

Summer/Winter Switch



Volt free Summer / Winter Switch (supplied with unit)
Polarity is inconsequential
Warning! - Do not connect to mains!

Electrical Details

Please note: the electrical connection of the unit must be carried out by a qualified electrician.

The unit is supplied with a flexible cord for connection to the mains supply. NOTE: This unit must be earthed.

The mains power supply cable should be connected to a fixed wiring installation, via a fused isolator, in accordance with current IEE wiring regulations.

Specification

MRXBOXAB-ECO2B-AE

SPECIFICATION

The unit shall be fully insulated providing excellent thermal and acoustic characteristics and shall be complete with a multi plate counter flow high efficiency heat exchanger block, with a thermal efficiency of up to 95%. The heat exchanger shall be protected by ISO Coarse filters on fresh air inlet and system extract. The heat exchanger and filters shall be accessible via the front access panel, enabling quick and easy maintenance. The unit shall have low energy, high efficiency EC fan/motor assemblies with sealed for life bearings, the impellers shall be backward curved centrifugal type. The motors shall be suitable of an ambient temperature of 40°C. The unit shall be supplied complete with a condensate drip tray and 21.5mm drain connection.

The unit shall be suitable for 125mm diameter circular ducting. The breakout noise level and power requirements shall be as detailed by the unit manufacturer and in accordance with the ventilation equipment schedule. Units shall be one of MRXBOXAB-ECO2B-AE or MRXBOXAB-ECO2B-AE-OH as manufactured by Nuair. The unit shall be provided within a white pre-painted or coated steel acoustic enclosure lined with a minimum of 20mm class '0' acoustic foam insulation to reduce breakout noise. Flexible duct connections shall be within the enclosure, pre-fitted between the MVHR unit and the connection spigots on the top face of the enclosure. (Removing the need for flexible duct connectors outside of the unit which may cause breakout). The MVHR unit shall be retained within the enclosure on a metal tray supported on turret type anti-vibration mounts of suitable deflection to ensure that vibration is not transmitted to the supporting structure. All operational components of the MVHR unit shall be accessible via the front panel of the enclosure. The enclosure shall be supported on 3mm (minimum) prefabricated steel cantilever wall brackets or other suitable fabricated steel supporting frame.

OPERATION FOR TWO SPEED (STANDARD MODEL)

The supply and extract ventilation unit shall be positioned as indicated on the drawings and shall be in accordance with the particular fan schedule in the specification. This unit is also available in Opposite Hand formatting. The combined supply and extract with heat recovery unit, shall supply filtered fresh air to each of the habitable rooms and vitiated air shall be extracted from the wet areas e.g. bathroom, en-suite, w.c, kitchen, utility rooms, etc. The supply air shall be pre-heated by the warm extract air via the integrated counter-flow heat exchanger element. The extracted air shall also be filtered before it reaches the heat exchanger block.

The ventilation unit shall vary its speed and, therefore, the ventilation rate, as it receives signals from one of the following:

- Switched live signal from light/remote switches/remote switch/humidistat switch.

When signals are received, the fan shall alter its speed to adjustable, normal and boost rates. The unit shall have the facility to commission the supply and extract fans independently on minimum speed (continuous background ventilation), and boost speed, via inbuilt minimum and maximum speed adjustment. The fans shall have infinitely variable speed control.

INTEGRAL AUTOMATIC SUMMER BYPASS

Including automatic 100% Summer Bypass where intake and return air temperatures shall be measured so that supply air temperatures can be maximised during winter months and minimised as external ambient temperature rises. The Summer Bypass damper shall be opened by a wax actuator. Supply and Extract air shall be filtered irrespective of the bypass setting (open or closed).

INTEGRAL HUMIDITY SENSOR

The integral humidity sensor incorporated within the extract fan chamber will automatically boost both the extract and supply fan, to the commissioned boost speed, when the humidity level exceeds that set by the front panel mounted adjustment potentiometer.

SUMMER/WINTER (SW) SWITCH THIRD SPEED

The unit shall feature volt-free connections for a positional switch controlling the bypass logic profile. Summer setting shall target under 20 degrees C internal dwelling temperature. Winter setting shall ensure heat recovery at all times. Temperature control logic shall be factory pre-set and require no on-site programming. The unit shall feature 3 commissionable speeds for both supply and extract. It shall be possible to enable the unit to its 3rd speed by means of a switch or a programmable thermostat with occupant override CM-THERM-CONTROL The 3rd speed (overheating) shall be inhibited when outside air temperature exceeds inside temperature and bypass closes so that extracted air cools incoming fresh air.

CONTROL OPTIONS

All versions shall have the following functions integrally mounted within the fan unit on a purpose made PCB, all such components pre-wired and factory fitted by the manufacturer:

- Independent control of background supply and extract flow rates.
- Independent control of boost speed supply and extract flow rates.
- Integral S/L terminal for boost from remote switch, e.g. light switch, kitchen boost switch.
- Integral heat exchanger frost protection.
- Discreet daily run monitor.
- Integral humidistat. (MRXBOXAB-ECO2B-AE & MRXBOXAB-ECO2B-AE-OH).

The unit comes with 2 years warranty (including parts and labour).

ALL IN ONE ACOUSTIC SOLUTION

MRXBOXAB-ECO2B-1Z

The MRXBOXAB-ECO2B-1Z is the all-in-one acoustic enclosure, allowing the MVHR unit and attenuator to be entirely encased.

With an aesthetically pleasing design enclosing the attenuator, flexible duct connections and anti-vibration mounts that would otherwise be visible, whilst making a significant reduction in case radiated noise.

The unit is equipped to commission the supply and extract fans independently on both minimum and maximum speeds, with the heat exchange blocks being able to recover up to 95% of the wasted heat that has been extracted from the 'wet areas' within the property and at the same time drawing in fresh supply air from outside.

The 1Z model is designed to provide optimised balanced (supply and extract) mechanical ventilation heat recovery, whilst offering the best all-in-one acoustic solution on the market.

Units are available as SW versions with a third controllable speed for Approved Document F&O purge rates and additional SW switch to select between seasonal bypass logic profiles.

Opposite Handed (OH) configuration available.



Installation Features:



Achieves
100%
duty in bypass
mode

Performance

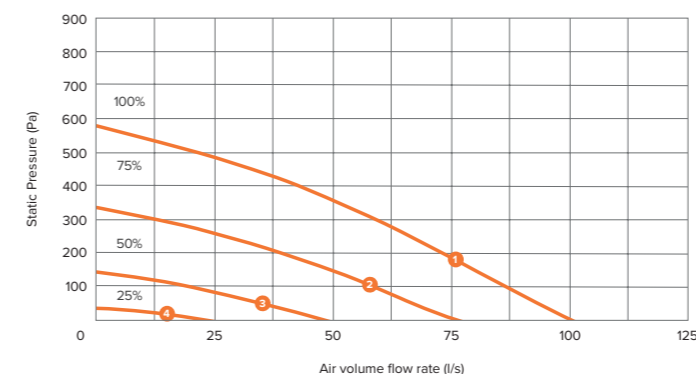

MRXBOXAB-ECO2B-1Z

Wall mounted unit with 100% bypass and integral humidistat.

MRXBOXAB-ECO2B-1Z-OH

Opposite Handed configuration wall mounted unit with 100% bypass and integral humidistat.

SUMMER/WINTER SWITCH ONLY (SW)

Units are available as SW versions with a third controllable speed and a Summer/Winter switch, allowing selection of seasonal bypass logic profiles.

Electrical & Sound

ECO2B-1Z Sound Data											
Curve	Maximum power consumption (Watts)		Sound Power Levels dB re 1pW (Frequency Hz)								dBA @3m
			63	125	250	500	1k	2k	4k	8k	
1	152	Open inlet	39	43	46	41	29	24	16	16	
		Open outlet	45	57	59	56	44	42	37	34	
		Breakout	57	59	49	44	28	18	16	16	29
2	67	Open inlet	35	35	43	36	23	17	16	16	
		Open outlet	41	52	52	53	39	34	31	26	
		Breakout	47	55	45	39	21	<16	<16	<16	24
3	20	Open inlet	32	29	34	27	<16	<16	<16	<16	
		Open outlet	33	43	43	43	29	23	18	<16	
		Breakout	37	46	37	30	<16	<16	<16	<16	<16
4	7	Open inlet	33	27	22	19	<16	<16	<16	<16	
		Open outlet	29	30	29	29	<16	<16	<16	<16	
		Breakout	33	32	24	17	<16	<16	<16	<16	<16

The maximum power consumption shown above (Watts) is consumed on units running continuously, not taking into account any heat recovery saving and based on SAP Product Characteristic Database (PCDB) testing. The breakout case-radiated dBA values are given for Hemispherical free field radiation at 3m - to obtain the Spherical radiated data, subtract 3 dBA.

Please note: Sound data is provided at a particular duty point for 25%, 50%, 75% and 100%. For accurate sound data at a specific speed duty please use Nuaire's fan selector or call the office on 029 2085 8500.

SAP/PCDB Data

Product Code	MRXBOXAB-ECO2B-1Z		
SAP Identifier	MRXBOXAB-ECO2B		
Application	Specific Fan Power (W/l/s)	Heat Exchange Efficiency	Energy Saving Trust Best Practice Compliant
Kitchen + 1 Wet Room	0.55	90%	Yes
Kitchen + 2 Wet Rooms	0.65	89%	Yes
Kitchen + 3 Wet Rooms	0.8	87%	Yes
Kitchen + 4 Wet Rooms	1.01	86%	Yes

Standard Model

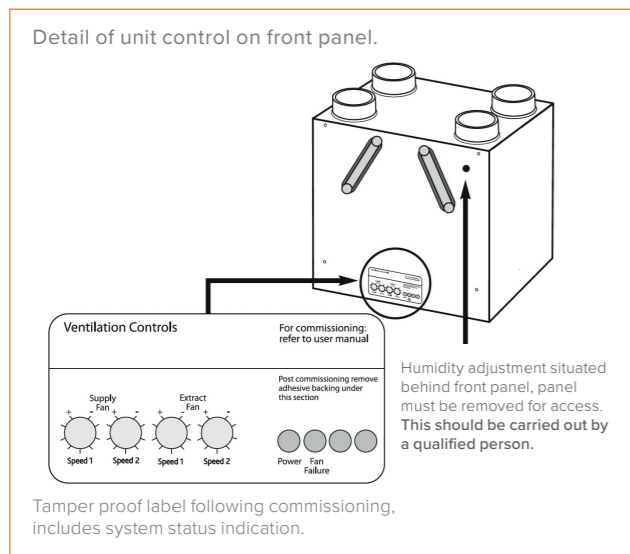

SW Model

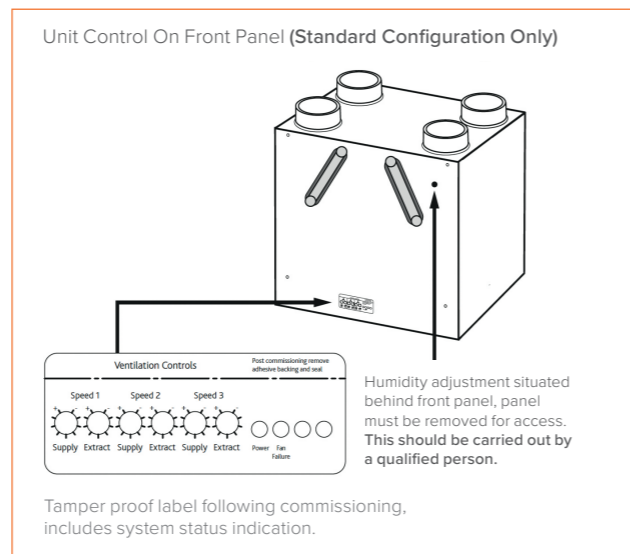

Handing Information

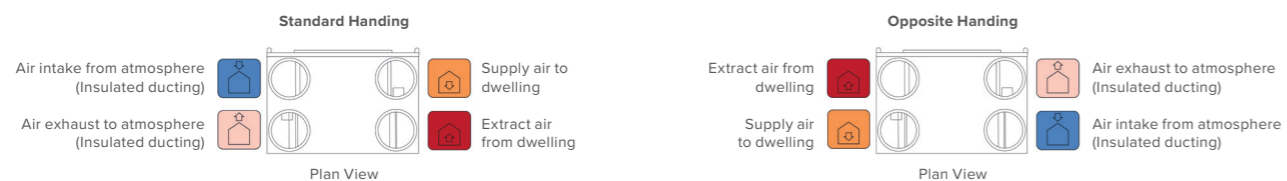

Technical – MRXBOXAB-ECO2B-1Z

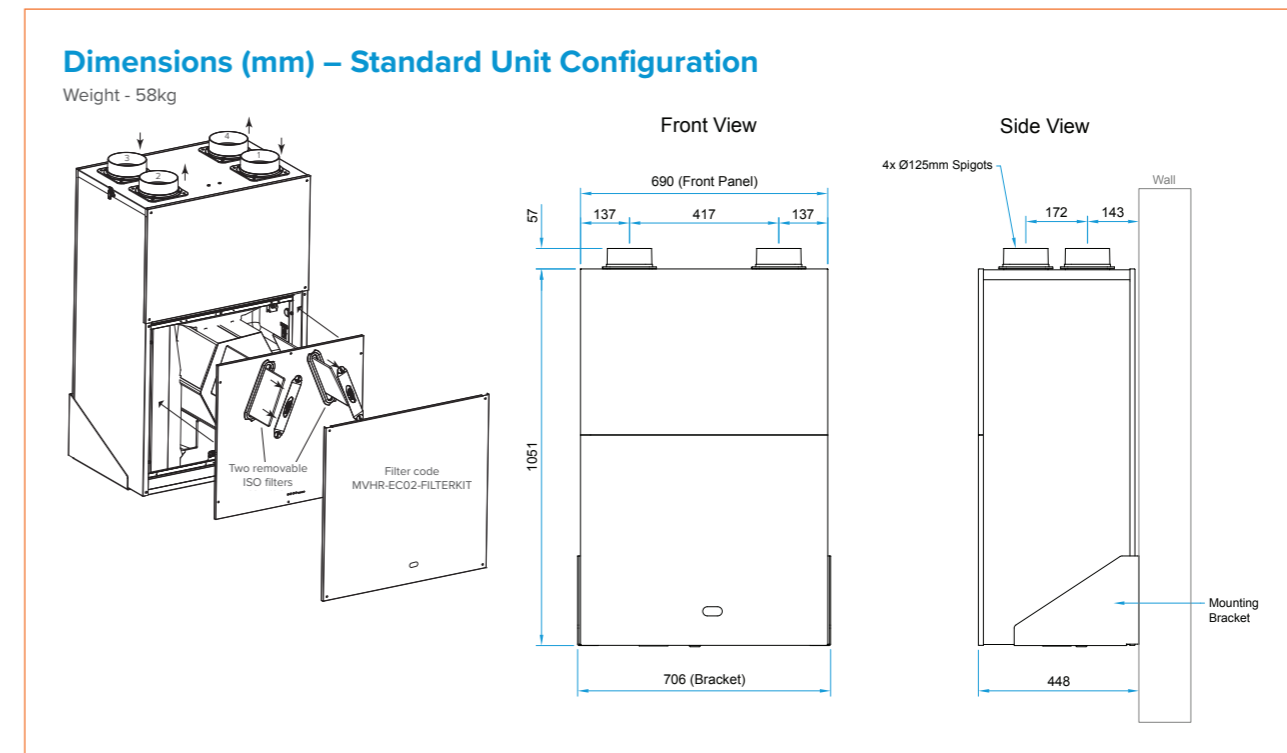

Ancillaries

MRXBOXAB-ECO2B-1Z

The MRXBOX-DB2 is fitted on top of the MRXBOXAB-ECO2B-1Z before installation and offers a neat arrangement by directly distributing the initial ducting. It further benefits this MVHR system by reducing any in-line noise breakout, therefore, improving this acoustic solution.

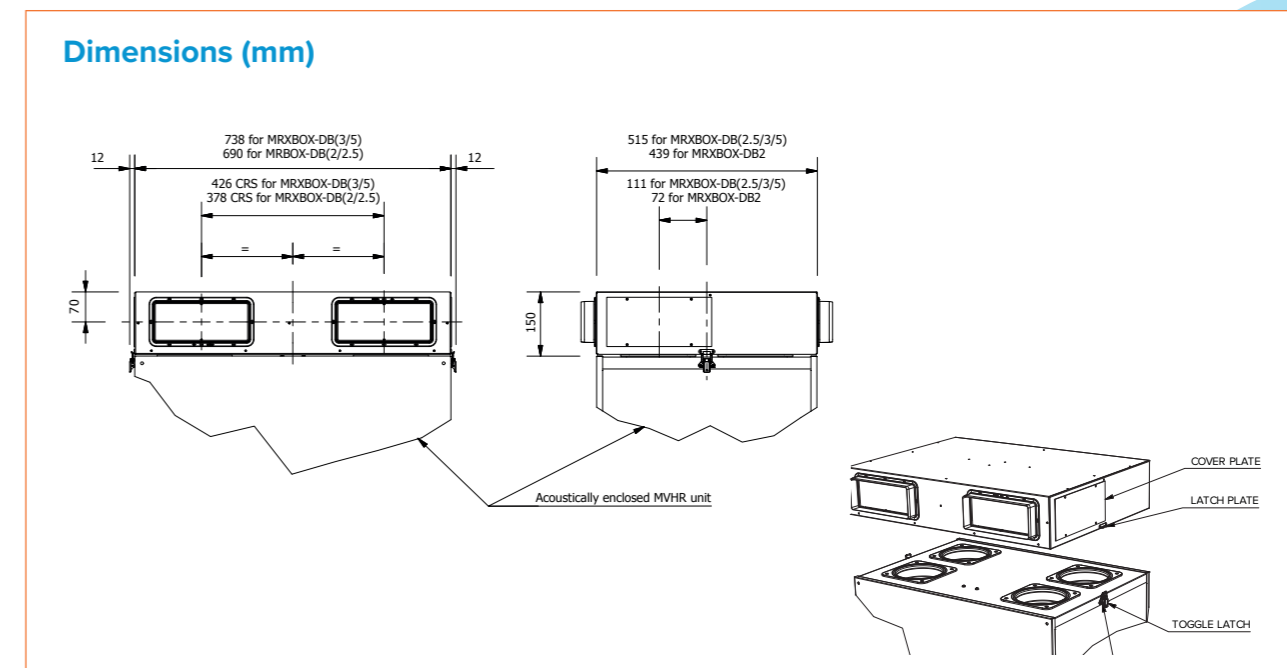

MRXBOXAB-ECO2B-1Z

Unit Serving Kitchen & Bathroom

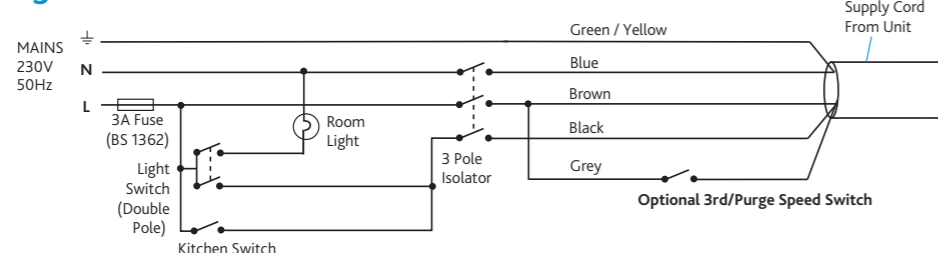

Unit Serving Kitchen & Two Bathrooms

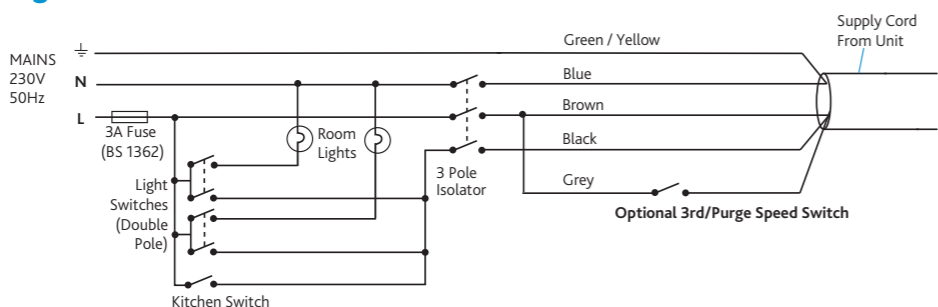

Summer/Winter Switch



Volt free Summer / Winter Switch (supplied with unit)
Polarity is inconsequential
Warning! - Do not connect to mains!

Electrical Details

Please note: the electrical connection of the unit must be carried out by a qualified electrician.

The unit is supplied with a flexible cord for connection to the mains supply. NOTE: This unit must be earthed.

The mains power supply cable should be connected to a fixed wiring installation, via a fused isolator, in accordance with current IEE wiring regulations.

Specification

MRXBOXAB-ECO2B-1Z

SPECIFICATION

The unit shall be fully insulated providing excellent thermal and acoustic characteristics and shall be complete with a multi plate counter flow high efficiency heat exchanger block, with a thermal efficiency of up to 95%. The heat exchanger shall be protected by ISO Coarse filters on fresh air inlet and system extract. The heat exchanger and filters shall be accessible via the front access panel, enabling quick and easy maintenance.

The unit shall have low energy, high efficiency EC fan/motor assemblies with sealed for life bearings, the impellers shall be backward curved centrifugal type. The motors shall be suitable of an ambient temperature of 40°C. The unit shall be supplied complete with a condensate drip tray and 21.5mm drain connection.

The unit shall be suitable for 125mm diameter circular ducting. The breakout noise level and power requirements shall be as detailed by the unit manufacturer and in accordance with the ventilation equipment schedule. Units shall be one of MRXBOXAB-ECO2B-1Z or MRXBOXAB-ECO2B-1Z-OH as manufactured by Nuair.

The unit shall be provided within a white pre-painted or coated steel acoustic enclosure lined with a minimum of 20mm class '0' acoustic foam insulation to reduce breakout noise.

In-duct noise shall be attenuated on Intake/Exhaust/Supply/Extract by means of a 4-way attenuator mounted within the enclosure and close coupled directly to the unit. Flexible duct connections shall be within the enclosure, pre-fitted between the attenuator section and the connection spigots on the top face of the enclosure. Removing the need for flexible duct connectors outside of the unit which may cause breakout. The MVHR unit and attenuator assembly shall be retained within the enclosure on a metal tray supported on turret type anti-vibration mounts of suitable deflection to ensure that vibration is not transmitted to the supporting structure. All operational components of the MVHR unit shall be accessible via the front panel of the enclosure. The enclosure shall be supported on 3mm (minimum) prefabricated steel cantilever wall brackets or other suitable fabricated steel supporting frame.

OPERATION FOR TWO SPEED (STANDARD MODEL)

The supply and extract ventilation unit shall be positioned as indicated on the drawings and shall be in accordance with the particular fan schedule in the specification. This unit is also available in Opposite Hand formatting.

The combined supply and extract with heat recovery unit, shall supply filtered fresh air to each of the habitable rooms and vitiated air shall be extracted from the wet areas e.g. bathroom, en-suite, w.c, kitchen, utility rooms, etc. The supply air shall be pre-heated by the warm extract air via the integrated counter-flow heat exchanger element. The extracted air shall also be filtered before it reaches the heat exchanger block.

The ventilation unit shall vary its speed and, therefore, the ventilation rate, as it receives signals from one of the following:

- Switched live signal from light/remote switches/remote switch/humidistat switch.

When signals are received, the fan shall alter its speed to adjustable, normal and boost rates. The unit shall have the facility to commission the supply and extract fans independently on minimum speed (continuous background ventilation), and boost speed, via inbuilt minimum and maximum speed adjustment. The fans shall have infinitely variable speed control.

INTEGRAL AUTOMATIC SUMMER BYPASS

Including automatic 100% Summer Bypass where intake and return air temperatures shall be measured so that supply air temperatures can be maximised during winter months and minimised as external ambient temperature rises. The Summer Bypass damper shall be opened by a wax actuator. Supply and Extract air shall be filtered irrespective of the bypass setting (open or closed).

INTEGRAL HUMIDITY SENSOR

The integral humidity sensor incorporated within the extract fan chamber will automatically boost both the extract and supply fan, to the commissioned boost speed, when the humidity level exceeds that set by the front panel mounted adjustment potentiometer.

SUMMER/WINTER (SW) SWITCH THIRD SPEED

The unit shall feature volt-free connections for a positional switch controlling the bypass logic profile. Summer setting shall target under 20 degrees C internal dwelling temperature. Winter setting shall ensure heat recovery at all times. Temperature control logic shall be factory pre-set and require no on-site programming. The unit shall feature 3 commissionable speeds for both supply and extract. It shall be possible to enable the unit to its 3rd speed by means of a switch or a programmable thermostat with occupant override CM-THERM-CONTROL. The 3rd speed (overheating) shall be inhibited when outside air temperature exceeds inside temperature and bypass closes so that extracted air cools incoming fresh air.

CONTROL OPTIONS

All versions are built in with the following functions integrally mounted within the fan unit on a purpose made PCB, all such components pre-wired and factory fitted by the manufacturer:

- Independent control of background supply and extract flow rates.
- Independent control of boost speed supply and extract flow rates.
- Integral S/L terminal for boost from remote switch, e.g. light switch, kitchen boost switch.
- Integral heat exchanger frost protection.
- Discreet daily run monitor.
- Integral humidistat. (MRXBOXAB-ECO2B-1Z & MRXBOXAB-ECO2B-1Z-OH).

The unit comes with 2 years warranty (including parts and labour).

ALL ROUND MVHR SOLUTIONS

MRXBOXAB-ECO3B

The MRXBOXAB-ECO3B is a wall mounted MVHR unit with 100% automatic bypass and integral humidistat as listed on the SAP Product Characteristics Database (PCDB).

Owing to its intelligent and smart design, there will be no reduction in airflow when operating in bypass mode, resulting in balanced performance. The unit is designed to provide optimised balanced (supply and extract) mechanical ventilation with heat recovery.

The two airflows pass through the heat exchanger where up to 95% of the heat from the extract air is transferred into the supply air before supplying into the habitable rooms, creating comfortable and well-ventilated homes. The two independent fans have infinitely variable speed control for background and boost ventilation rates.

The ECO3B has a Summer Bypass function which automatically activates in warmer months to ensure the property is well-ventilated and comfort levels are maintained in the home by continuously drawing in fresh

filtered air into the habitable rooms. The unit is compact enough to go into a cupboard space, as well as being powerful enough to ventilate kitchen and up to 6 wet rooms.

Units are available as SW versions with a third controllable speed for Approved Document F&O purge rates and additional SW switch to select between seasonal bypass logic profiles.

Opposite Handed (OH) configuration available.



Performance

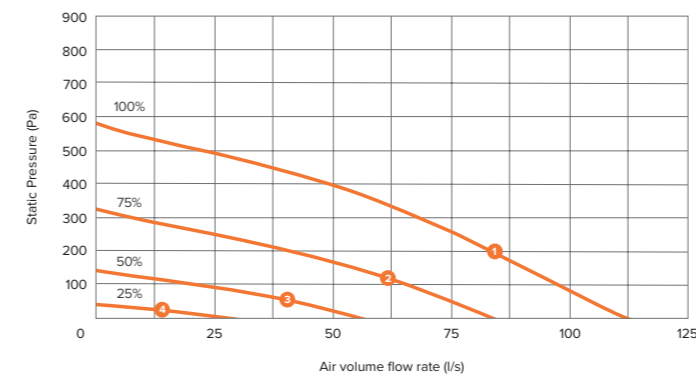

MRXBOXAB-ECO3B

Wall mounted unit with 100% bypass and integral humidistat.

MRXBOXAB-ECO3B-OH

Opposite Handed configuration wall mounted unit with 100% bypass and integral humidistat.

SUMMER/WINTER SWITCH ONLY (SW)

Units are available as SW versions with a third controllable speed and a Summer/Winter switch, allowing selection of seasonal bypass logic profiles.

Electrical & Sound

ECO3B Sound Data											
Curve	Maximum power consumption (Watts)		Sound Power Levels dB re 1pW (Frequency Hz)								dBA @3m
			63	125	250	500	1k	2k	4k	8k	
1	169	Open inlet	47	58	61	56	51	46	33	26	
		Open outlet	57	66	65	68	65	64	57	48	
		Breakout	64	59	60	61	53	49	38	27	42
2	71	Open inlet	43	53	58	52	48	42	29	20	
		Open outlet	54	62	61	65	62	61	52	42	
		Breakout	54	56	54	55	47	44	29	16	36
3	21	Open inlet	39	45	49	43	37	30	<16	<16	
		Open outlet	46	53	51	55	50	47	36	24	
		Breakout	48	47	46	46	37	32	18	<16	27
4	7	Open inlet	33	29	29	22	<16	<16	<16	<16	
		Open outlet	39	36	34	37	28	20	<16	<16	
		Breakout	42	31	30	26	<16	<16	<16	<16	<16

The maximum power consumption shown above (Watts) is consumed on units running continuously, not taking into account any heat recovery saving and based on SAP Product Characteristics Database (PCDB) testing. The breakout case-radiated dBA values are given for Hemispherical free field radiation at 3m – to obtain the Spherical radiated data, subtract 3 dBA.

Please note: Sound data is provided at a particular duty point for 25%, 50%, 75% and 100%. For accurate sound data at a specific speed duty, please use Nuair's fan selector or call the office on 029 2085 8500.

Installation Features:



Achieves
100%
duty in bypass
mode

SAP/PCDB Data

Product Code	MRXBOXAB-ECO3B		
SAP Identifier	MRXBOXAB-ECO3B		
Application	Specific Fan Power (W/l/s)	Heat Exchange Efficiency	Energy Saving Trust Best Practice Compliant
Kitchen + 1 Wet Room	0.56	90%	Yes
Kitchen + 2 Wet Rooms	0.58	90%	Yes
Kitchen + 3 Wet Rooms	0.65	89%	Yes
Kitchen + 4 Wet Rooms	0.79	88%	Yes
Kitchen + 5 Wet Rooms	0.95	88%	Yes

Standard Model

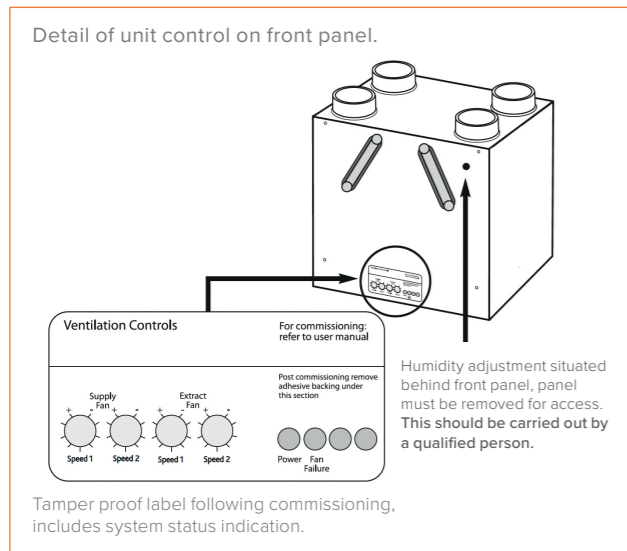

SW Model

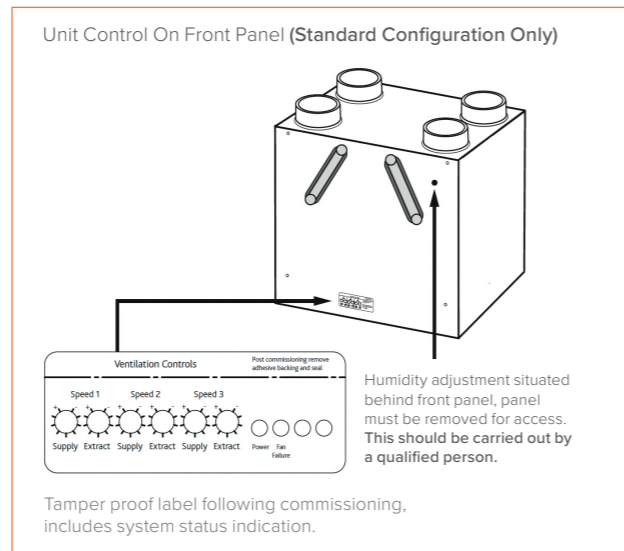

Handing Information

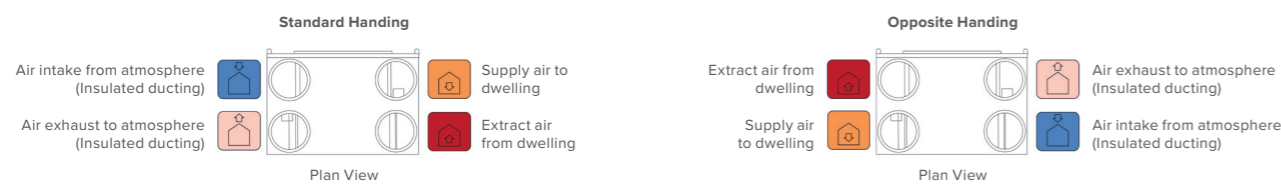

Technical – MRXBOXAB-ECO3B

Dimensions (mm) – Standard Unit Configuration

Weight - 24kg

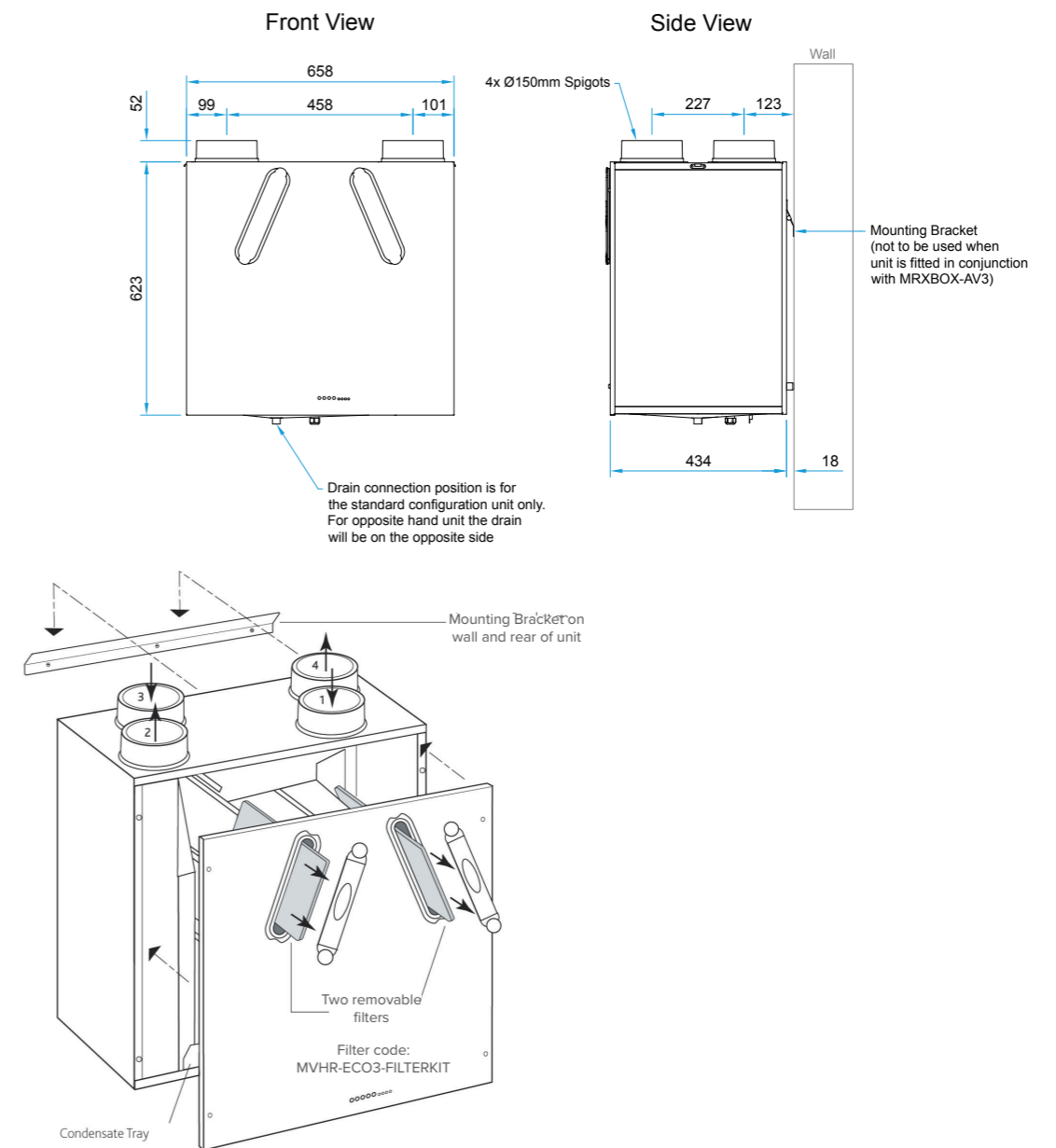

Wiring – MRXBOXAB-ECO3B

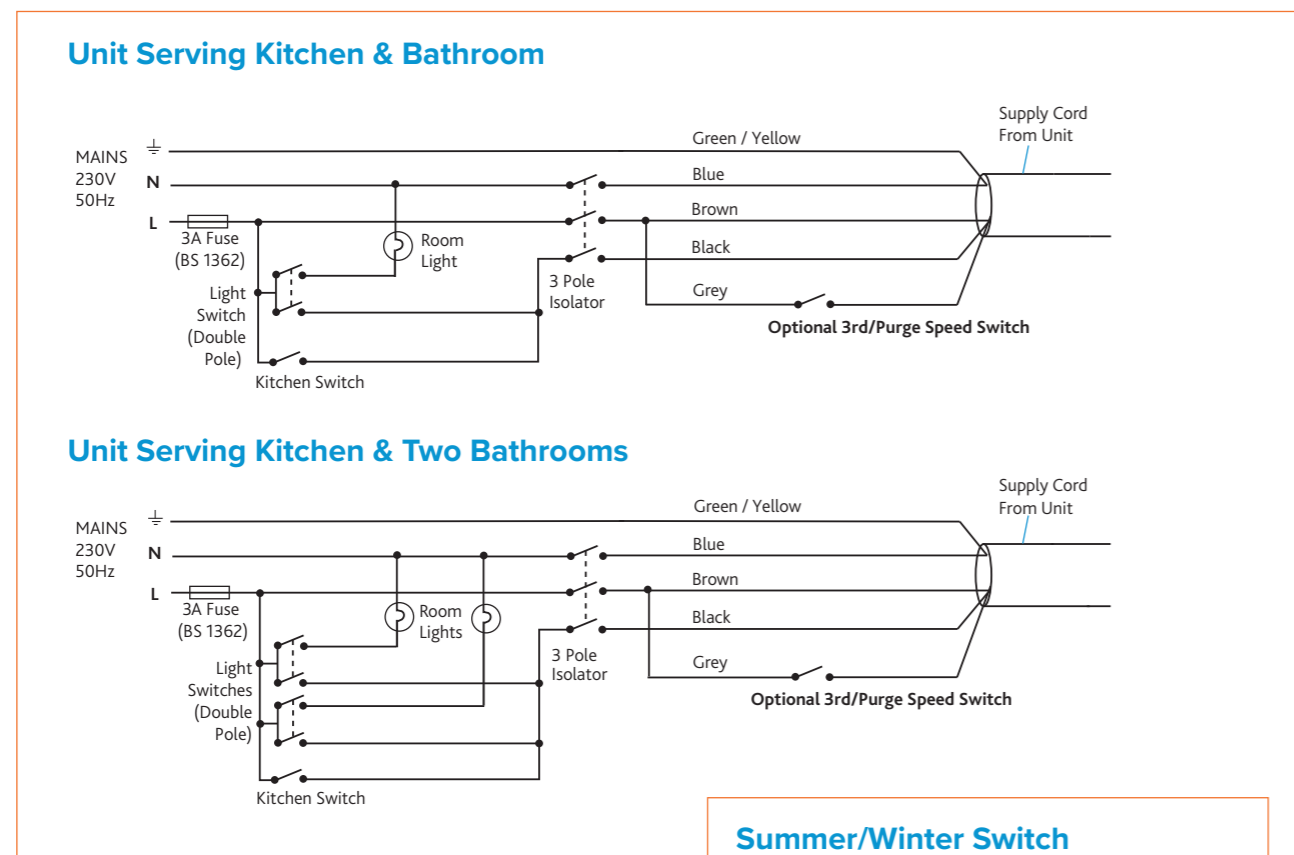

Electrical Details

Please note: the electrical connection of the unit must be carried out by a qualified electrician.

The unit is supplied with a flexible cord for connection to the mains supply. NOTE: This unit must be earthed.

The mains power supply cable should be connected to a fixed wiring installation, via a fused isolator, in accordance with current IEE wiring regulations.

Summer/Winter Switch



Volt free Summer / Winter Switch (supplied with unit)
Polarity is inconsequential
Warning! - Do not connect to mains!

Specification

MRXBOXAB-ECO3B

SPECIFICATION

The unit shall be fully insulated providing excellent thermal and acoustic characteristics and shall be complete with a multiplate, counter-flow, high-efficiency heat exchanger block, with a thermal efficiency of up to 95%. The heat exchanger shall be protected by ISO Coarse filters on fresh air inlet and system extract. The heat exchanger and filters shall be accessible via the front access panel, enabling quick and easy maintenance.

The unit shall have low energy, high-efficiency EC fan/motor assemblies with sealed for life bearings, the impellers shall be backward curved centrifugal type. The motors shall be suitable for an ambient temperature of 40°C. The unit shall be supplied connection. The unit shall be suitable for 150mm circular ducting. Note: The unit is also available in Opposite Handed format, refer to spigot configuration for set up.

The breakout noise level and power requirements shall be as detailed by the unit manufacturer and in accordance with the ventilation equipment schedule. Units shall be MRXBOXAB-ECO3B as manufactured by Nuaire and shall be listed on the SAP PCDB. MRXBOXAB-ECO3B-OH are Opposite Handed assemblies compliant as per standard handed versions listed in SAP PCDB.

OPERATION FOR TWO SPEED (STANDARD MODEL)

The supply and extract system shall be positioned as indicated on the drawings and shall be in accordance with the particular fan schedule in the specification.

The combined supply and extract with heat recovery unit shall supply filtered fresh air to each of the habitable rooms and moisture-laden air shall be extracted from all wet areas, e.g. bathroom, en suite, w.c, kitchen, utility rooms etc. The supply air shall be pre-heated by the warm extract air via the integrated counter-flow heat exchanger element. The extracted air shall also be filtered before it reaches the heat exchanger block.

The ventilation unit shall vary its speed and, therefore, the ventilation rate, as it receives signals from one of the following:

- Switched live signal from light/remote switches/remote switch/humidistat switch.

When signals are received, the fan shall alter its speed to adjustable, normal and boost rates. The unit shall have the facility to commission the supply and extract fans independently on minimum speed (continuous background ventilation) and boost speed via inbuilt minimum and maximum speed adjustment. The fans shall have infinitely variable speed control.

INTEGRAL AUTOMATIC HX BYPASS WITH NO REDUCTION IN AIRFLOW

The bypass damper shall open automatically via a wax actuator, allowing the air to bypass the heat exchanger to deliver fresh filtered air during the warmer months. The automatic bypass diverts 100% airflow around the heat exchanger with no reduction in airflow as independently tested by the BRE.

INTEGRAL HUMIDITY SENSOR

The integral humidity sensor incorporated within the extract fan chamber will automatically boost both the extract and supply fan, to the commissioned boost speed, when the humidity level exceeds that set by the front panel mounted adjustment potentiometer.

SUMMER/WINTER (SW) SWITCH THIRD SPEED

The unit shall feature volt-free connections for a positional switch controlling the bypass logic profile. Summer setting shall target under 20 degrees C internal dwelling temperature. Winter setting shall ensure heat recovery at all times. Temperature control logic shall be factory pre-set and require no on-site programming. The unit shall feature 3 commissionable speeds for both supply and extract. It shall be possible to enable the unit to its 3rd speed by means of a switch or a programmable thermostat with occupant override CM-THERM-CONTROL. The 3rd speed (overheating) shall be inhibited when outside air temperature exceeds inside temperature and bypass closes so that extracted air cools incoming fresh air.

CONTROL OPTIONS

All versions are built in with the following functions integrally mounted within the fan unit on a purpose made PCB, all such components are pre-wired and factory fitted by the manufacturer:

- Independent control of background supply and extract flow rates.
- Independent control of boost speed supply and extract flow rates.
- Integral heat exchanger frost protection.
- Run/fault indication to external control systems/BMS via ES-VF.
- Integral S/L terminal for boost from remote switch, e.g. light switch.
- Additional S/L terminal for 100% boost speed from remote switch, e.g. plate switch.
- Discreet daily run monitor.
- Indication and controls – The unit shall have clear LED visual indication for maintenance, servicing and operation mode, i.e. HX bypass, frost protection.

The unit comes with 2 years warranty (including parts and labour).

ACOUSTIC SOLUTIONS

MRXBOXAB-ECO3B

Nuaire's First Fix and Acoustic Solutions are designed to not only reduce noise but to improve the installation when wall or cupboard mounting the MRXBOXAB-ECO3B unit.

Offering the only complete MVHR acoustic and first fix solution to overcome both noise and ease of installation. The acoustic solution addresses ducting noise and is an aesthetically pleasing design for cupboard installation.

Opposite Handed (OH) units available.

- Section 1** - First fix plenum chamber
- Section 2** - Silencer box has four airflow chambers, reducing induct noise
- Section 3** - MVHR unit

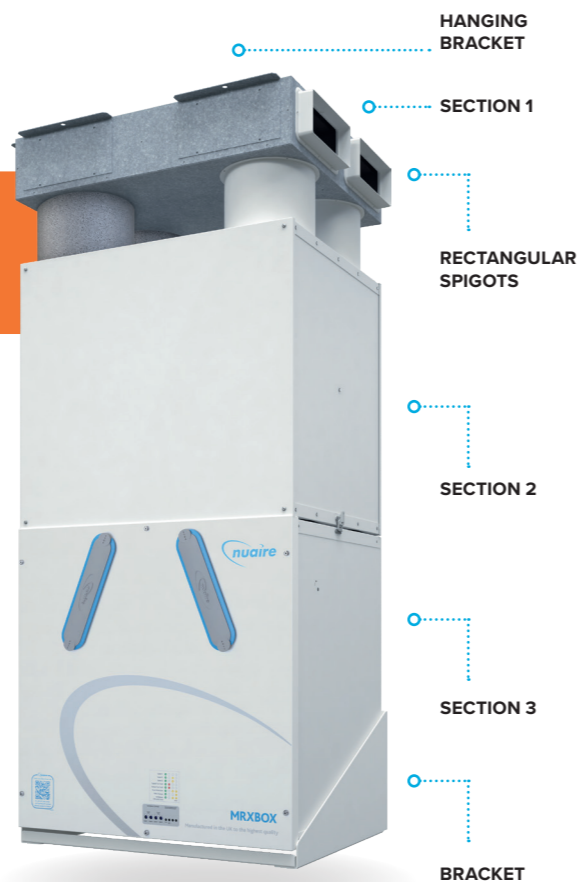

Installation Features:



Typical cupboard installation of MRXBOXAB-ECO3B

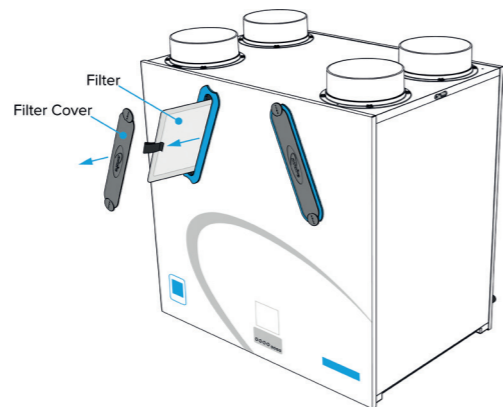

Acoustic data for MRXBOXAB-ECO3B with Silencer and/or First Fix box

Ancillary Sound Data								
MRXBOX-SIL3	63	125	250	500	1K	2K	4K	8K
SUPPLY/DISCHARGE	-11	-10	-9	-14	-23	-26	-20	-15
INTAKE/EXTRACT	-8	-10	-9	-10	-22	-24	-16	-13
MRXBOX-FF3								
SUPPLY/DISCHARGE	-8	-5	-4	-7	-7	-7	-6	-6
INTAKE/EXTRACT	-4	-7	-5	-6	-7	-7	-6	-4
MRXBOX-SIL3+ FF3								
SUPPLY/DISCHARGE	-18	-18	-18	-25	-30	-35	-28	-26
INTAKE/EXTRACT	-12	-20	-15	-16	-22	-24	-19	-16

Technical – MRXBOXAB-ECO3B

Dimensions (mm)

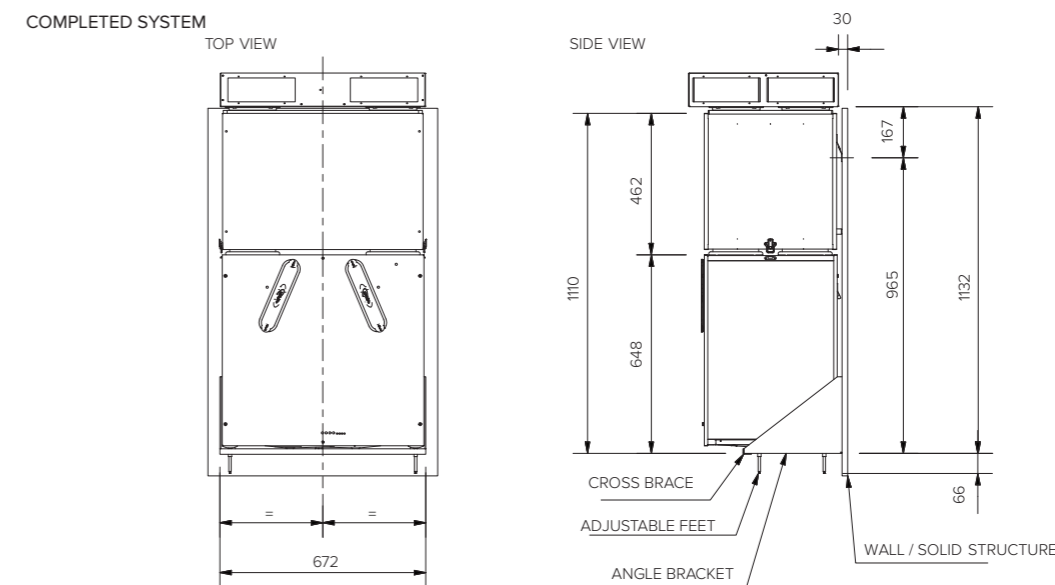
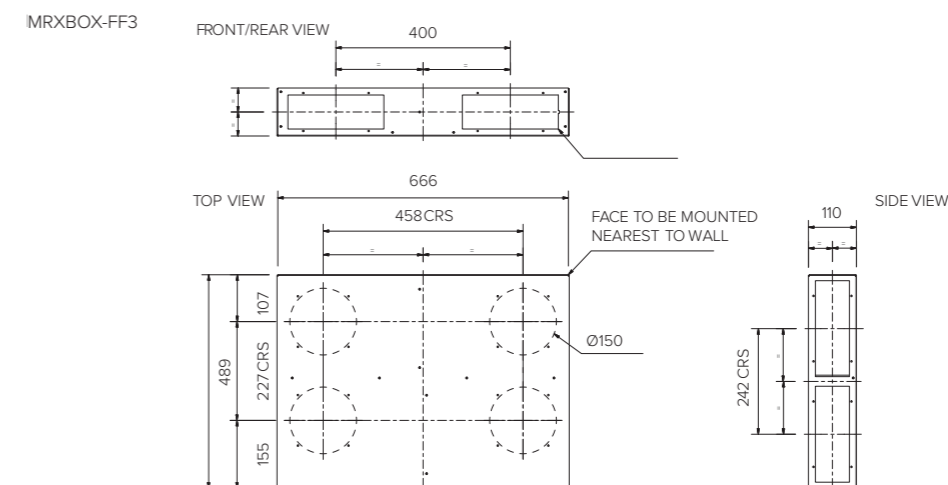
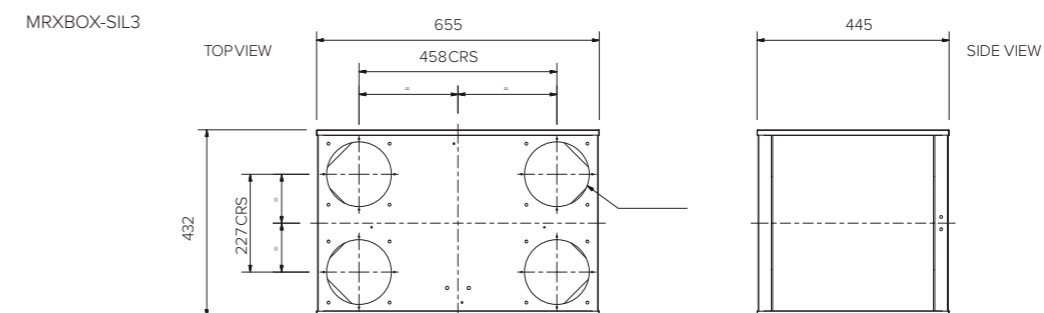

ACOUSTIC ENCLOSURE

MRXBOXAB-ECO3B-AE

The AE is a wall mounted MVHR unit with a factory fitted acoustic enclosure. Flexible duct connections and anti-vibration mounts are incorporated within the AE, providing vibration isolation from the supporting structure and significantly reducing case radiated noise, even at high running speeds.



The unit is equipped to commission the supply and extract fans independently on both minimum and maximum speeds, with the heat exchange blocks being able to recover up to 95% of the wasted heat that has been extracted from the 'wet areas' within the property and at the same time drawing in fresh supply air from outside.

Units are available as SW versions with a third controllable speed for Approved Document F&O purge rates and additional SW switch to select between seasonal bypass logic profiles.

Opposite Handed (OH) configuration available.

The two independent fans have infinitely variable speed control for background and boost ventilation rates. Units with additional Summer / Winter (SW) switch control are third speed enabled for purge ventilation rates. Nuaire guarantee that 100% design airflow rate is maintained in bypass operation.



Installation Features:



Performance

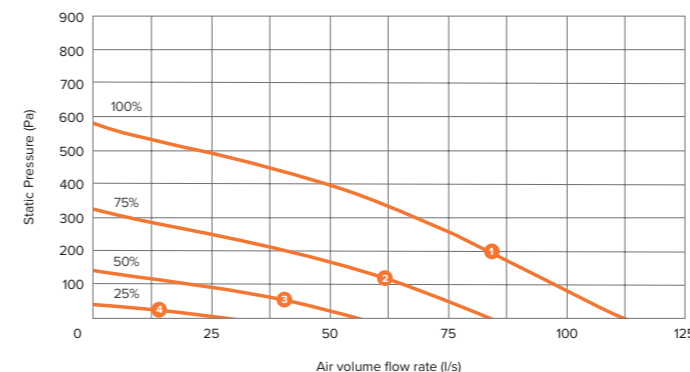

MRXBOXAB-ECO3B-AE

Wall mounted unit with 100% bypass and integral humidistat.

MRXBOXAB-ECO3B-AE-OH

Opposite Handed configuration wall mounted unit with 100% bypass and integral humidistat.

SUMMER/WINTER SWITCH ONLY (SW)

Units are available as SW versions with a third controllable speed and a Summer/Winter switch, allowing selection of seasonal bypass logic profiles.

Electrical & Sound

ECO3B-AE Sound Data											
Curve	Power consumption (Watts)		Sound Power Levels dB re 1pW (Frequency Hz)								dBa @3m
			63	125	250	500	1k	2k	4k	8k	
1	169	Open inlet	47	58	61	56	51	46	33	26	
		Open outlet	57	66	65	68	65	64	57	48	
		Breakout	59	57	52	46	29	20	<16	<16	29
2	71	Open inlet	43	53	58	52	48	42	29	20	
		Open outlet	54	62	61	65	62	61	52	42	
		Breakout	49	54	46	40	23	<16	<16	<16	24
3	21	Open inlet	39	45	49	43	37	30	<16	<16	
		Open outlet	46	53	51	55	50	47	36	24	
		Breakout	43	45	38	31	<16	<16	<16	<16	<16
4	7	Open inlet	33	29	29	22	<16	<16	<16	<16	
		Open outlet	39	36	34	37	28	20	<16	<16	
		Breakout	40	30	26	17	<16	<16	<16	<16	<16

The maximum power consumption shown above (Watts) is consumed on units running continuously, not taking into account any heat recovery saving and based on SAP Product Characteristics Database (PCDB) testing. The breakout case-radiated dBA values are given for Hemispherical free field radiation at 3m – to obtain the Spherical radiated data, subtract 3 dBA.

Please note: Sound data is provided at a particular duty point for 25%, 50%, 75% and 100%. For accurate sound data at a specific speed duty please use Nuaire's fan selector or call the office on 029 2085 8500.

SAP/PCDB Data

Product Code	MRXBOXAB-ECO3B-AE		
SAP Identifier	MRXBOXAB-ECO3B		
Application	Specific Fan Power (W/l/s)	Heat Exchange Efficiency	Energy Saving Trust Best Practice Compliant
Kitchen + 1 Wet Room	0.56	90%	Yes
Kitchen + 2 Wet Rooms	0.58	90%	Yes
Kitchen + 3 Wet Rooms	0.65	89%	Yes
Kitchen + 4 Wet Rooms	0.79	88%	Yes
Kitchen + 5 Wet Rooms	0.95	88%	Yes

Standard Model

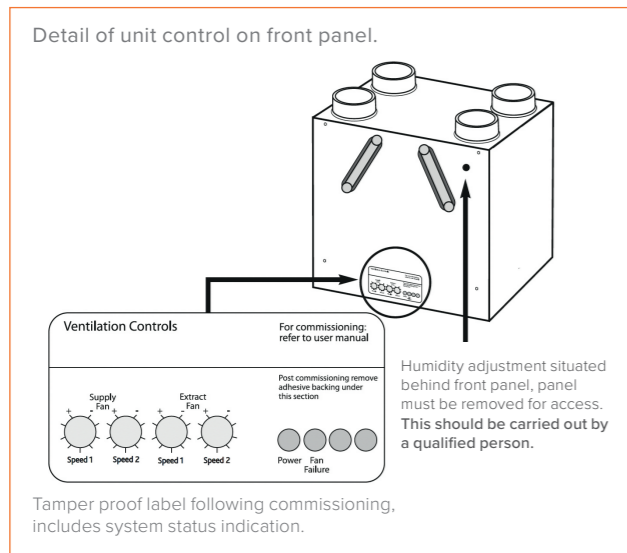

SW Model

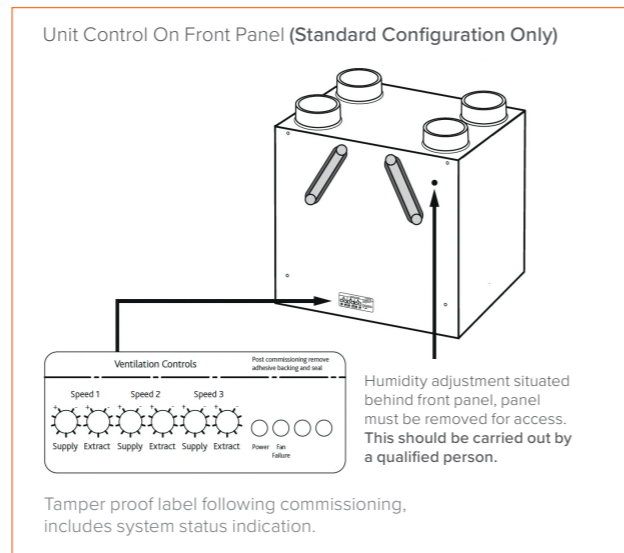

Handing Information

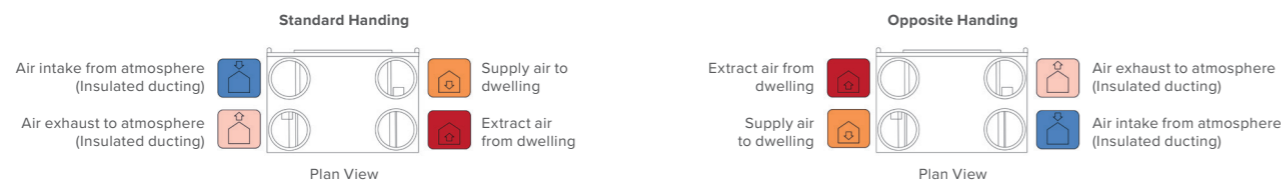

Technical – MRXBOXAB-ECO3B-AE

Dimensions (mm) – Standard Unit Configuration

Weight - 56kg

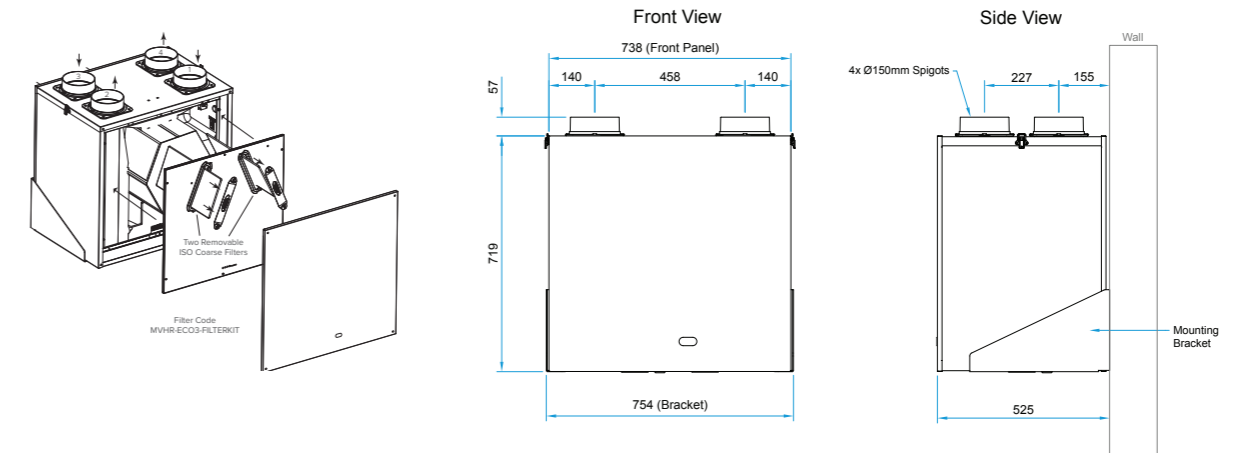

Ancillaries

MRXBOXAB-ECO3B-AE

The MRXBOX-DB3 is fitted on top of the MRXBOXAB-ECO3B-AE before installation and offers a neat arrangement by directly distributing the initial ducting. It further benefits this MVHR system by reducing any in-line noise breakout, therefore, improving this acoustic solution.

Dimensions (mm)

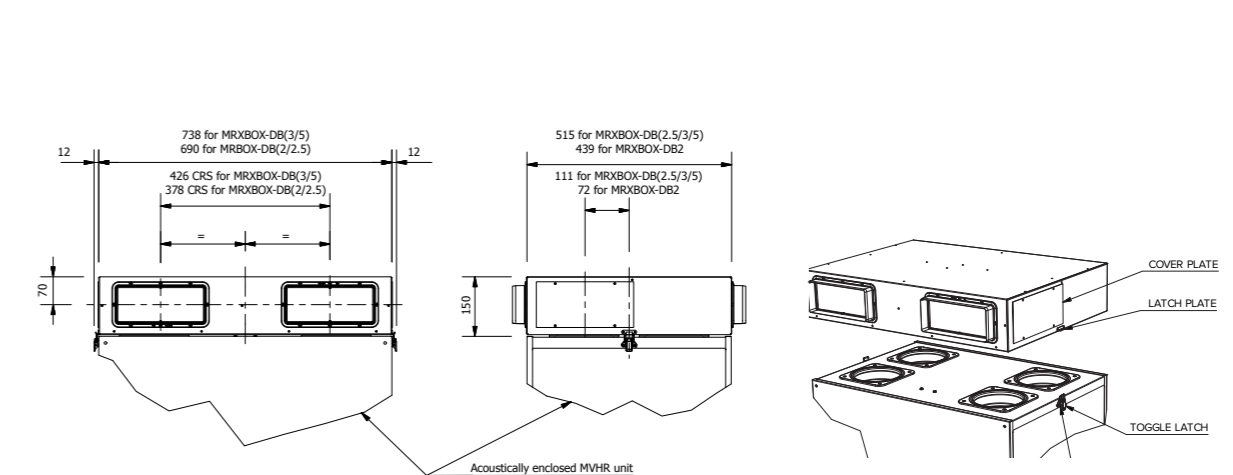

Wiring – MRXBOXAB-ECO3B-AE

Unit Serving Kitchen & Bathroom

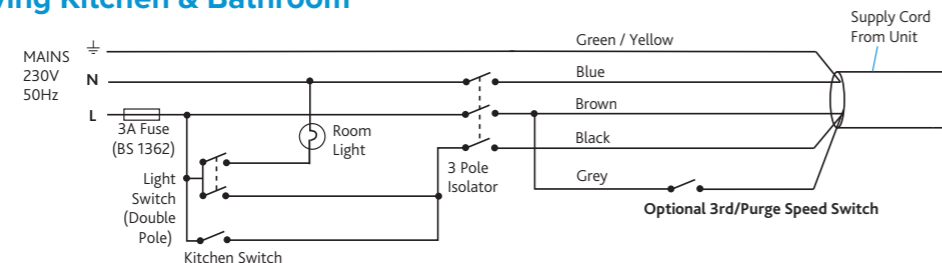

Unit Serving Kitchen & Two Bathrooms

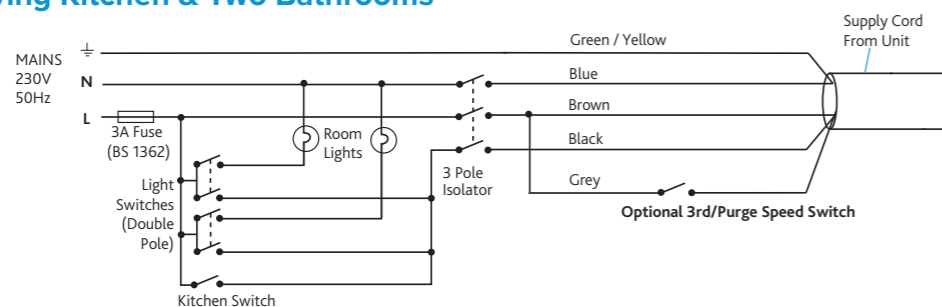

Summer/Winter Switch



Volt free Summer / Winter Switch (supplied with unit)
Polarity is inconsequential
Warning! - Do not connect to mains!

Electrical Details

Please note: the electrical connection of the unit must be carried out by a qualified electrician.

The unit is supplied with a flexible cord for connection to the mains supply. NOTE: This unit must be earthed.

The mains power supply cable should be connected to a fixed wiring installation, via a fused isolator, in accordance with current IEE wiring regulations.

Specification

MRXBOXAB-ECO3B-AE

SPECIFICATION

The unit shall be fully insulated providing excellent thermal and acoustic characteristics and shall be complete with a multi plate counter flow high efficiency heat exchanger block, with a thermal efficiency of up to 95%. The heat exchanger shall be protected by ISO Coarse filters on fresh air inlet and system extract. The heat exchanger and filters shall be accessible via the front access panel, enabling quick and easy maintenance.

The unit shall have low energy, high efficiency EC fan/motor assemblies with sealed for life bearings, the impellers shall be backward curved centrifugal type. The motors shall be suitable of an ambient temperature of 40°C. The unit shall be supplied complete with a condensate drip tray and 21.5mm drain connection. The unit shall be suitable for 150mm diameter circular ducting. The breakout noise level and power requirements shall be as detailed by the unit manufacturer and in accordance with the ventilation equipment schedule. Units shall be one of MRXBOXAB-ECO3B-AE, MRXBOXAB-ECO3B-AE-OH, as manufactured by Nuair. The unit shall be provided within a white pre-painted or coated steel acoustic enclosure lined with a minimum of 20mm class '0' acoustic foam insulation to reduce breakout noise.

Flexible duct connections shall be within the enclosure, pre-fitted between the MVHR unit and the connection spigots on the top face of the enclosure. (Removing the need for flexible duct connectors outside of the unit which may cause breakout). The MVHR unit shall be retained within the enclosure on a metal tray supported on turret type anti-vibration mounts of suitable deflection to ensure that vibration is not transmitted to the supporting structure. All operational components of the MVHR unit shall be accessible via the front panel of the enclosure. The enclosure shall be supported on 3mm (minimum) prefabricated steel cantilever wall brackets or other suitable fabricated steel supporting frame.

OPERATION FOR TWO SPEED (STANDARD MODEL)

The supply and extract ventilation unit shall be positioned as indicated on the drawings and shall be in accordance with the particular fan schedule in the specification. This unit is also available in Opposite Hand formatting. The combined supply and extract with heat recovery unit, shall supply filtered fresh air to each of the habitable rooms and vitiated air shall be extracted from the wet areas e.g. bathroom, en-suite, w.c, kitchen, utility rooms, etc. The supply air shall be pre-heated by the warm extract air via the integrated counter-flow heat exchanger element. The extracted air shall also be filtered before it reaches the heat exchanger block.

The ventilation unit shall vary its speed and, therefore, the ventilation rate, as it receives signals from one of the following:

- Switched live signal from light/remote switches/remote switch/humidistat switch.

When signals are received, the fan shall alter its speed to adjustable, normal and boost rates. The unit shall have the facility to commission the supply and extract fans independently on minimum speed (continuous background ventilation), and boost speed, via inbuilt minimum and maximum speed adjustment. The fans shall have infinitely variable speed control.

INTEGRAL AUTOMATIC SUMMER BYPASS

Including Automatic 100% Summer Bypass where intake and return air temperatures shall be measured so that supply air temperatures can be maximised during winter months and minimised as external ambient temperature rises. The Summer Bypass damper shall be opened by a wax actuator. Supply and Extract air shall be filtered irrespective of the bypass setting (open or closed).

INTEGRAL HUMIDITY SENSOR

The integral humidity sensor incorporated within the extract fan chamber will automatically boost both the extract and supply fan, to the commissioned boost speed, when the humidity level exceeds that set by the front panel mounted adjustment potentiometer.

SUMMER/WINTER (SW) SWITCH THIRD SPEED

The unit shall feature volt-free connections for a positional switch controlling the bypass logic profile. Summer setting shall target under 20 degrees C internal dwelling temperature. Winter setting shall ensure heat recovery at all times. Temperature control logic shall be factory pre-set and require no on-site programming. The unit shall feature 3 commissionable speeds for both supply and extract. It shall be possible to enable the unit to its 3rd speed by means of a switch or a programmable thermostat with occupant override CM-THERM-CONTROL. The 3rd speed (overheating) shall be inhibited when outside air temperature exceeds inside temperature and bypass closes so that extracted air cools incoming fresh air.

CONTROL OPTIONS

All versions are built in with the following functions integrally mounted within the fan unit on a purpose made PCB, all such components prewired and factory fitted by the manufacturer:

- Independent control of background supply and extract flow rates.
- Independent control of boost speed supply and extract flow rates.
- Integral S/L terminal for boost from remote switch, e.g. light switch, kitchen boost switch.
- Integral heat exchanger frost protection.
- Discreet daily run monitor.
- Integral humidistat.

The unit comes with 2 years warranty (including parts and labour).

ALL IN ONE ACOUSTIC SOLUTION

MRXBOXAB-ECO3B-1Z

The MRXBOXAB-ECO3B-1Z is the all-in-one acoustic enclosure, allowing the MVHR unit and attenuator to be entirely encased.

With an aesthetically pleasing design enclosing the attenuator, flexible duct connections and anti-vibration mounts that would otherwise be visible whilst making a significant reduction in case radiated noise.

The unit is equipped to commission the supply and extract fans independently on both minimum and maximum speeds, with the heat exchange blocks being able to recover up to 95% of the wasted heat that has been extracted from the 'wet areas' within the property and at the same time drawing in fresh supply air from outside.

The 1Z model is designed to provide optimised balanced (supply and extract) mechanical ventilation heat recovery, whilst offering the best all-in-one acoustic solution on the market.

Units are available as SW versions with a third controllable speed for Approved Document F&O purge rates and additional SW switch to select between seasonal bypass logic profiles.

Opposite Handed (OH) configuration available.



Performance

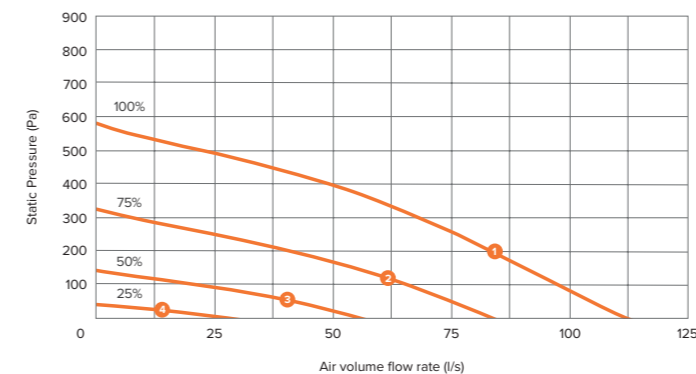

MRXBOXAB-ECO3B-1Z

Wall mounted unit with 100% bypass and integral humidistat.

MRXBOXAB-ECO3B-1Z-OH

Opposite Handed configuration wall mounted unit with 100% bypass and integral humidistat.

SUMMER/WINTER SWITCH ONLY (SW)

Units are available as SW versions with a third controllable speed and a Summer/Winter switch, allowing selection of seasonal bypass logic profiles.

Electrical & Sound

ECO3B-1Z Sound Data											
Curve	Maximum power consumption (Watts)		Sound Power Levels dB re 1pW (Frequency Hz)								dBA @3m
			63	125	250	500	1k	2k	4k	8k	
1	169	Open inlet	39	48	46	40	29	22	16	<16	
		Open outlet	43	56	54	54	42	38	37	33	
		Breakout	59	57	52	46	29	20	<16	<16	29
2	71	Open inlet	35	43	43	36	26	18	<16	<16	
		Open outlet	40	52	50	51	39	35	32	27	
		Breakout	49	54	46	40	23	<16	<16	<16	24
3	21	Open inlet	31	35	34	27	<16	<16	<16	<16	
		Open outlet	32	43	40	41	27	21	16	<16	
		Breakout	43	45	38	31	<16	<16	<16	<16	<16
4	7	Open inlet	29	23	21	<16	<16	<16	<16	<16	
		Open outlet	31	30	28	29	<16	<16	<16	<16	
		Breakout	38	30	26	17	<16	<16	<16	<16	<16

The maximum power consumption shown above (Watts) is consumed on units running continuously, not taking into account any heat recovery saving and based on SAP Product Characteristics Database (PCDB) testing. The breakout case-radiated dBA values are given for Hemispherical free field radiation at 3m – to obtain the Spherical radiated data, subtract 3 dBA.

Please note: Sound data is provided at a particular duty point for 25%, 50%, 75% and 100%. For accurate sound data at a specific speed duty, please use Nuaire's fan selector or call the office on 029 2085 8500.

Installation Features:



Achieves
100%
duty in bypass
mode

SAP/PCDB Data

Product Code	MRXBOXAB-ECO3B-1Z		
SAP Identifier	MRXBOXAB-ECO3B		
Application	Specific Fan Power (W/l/s)	Heat Exchange Efficiency	Energy Saving Trust Best Practice Compliant
Kitchen + 1 Wet Room	0.56	90%	Yes
Kitchen + 2 Wet Rooms	0.58	90%	Yes
Kitchen + 3 Wet Rooms	0.65	89%	Yes
Kitchen + 4 Wet Rooms	0.79	88%	Yes
Kitchen + 5 Wet Rooms	0.95	88%	Yes

Standard Model

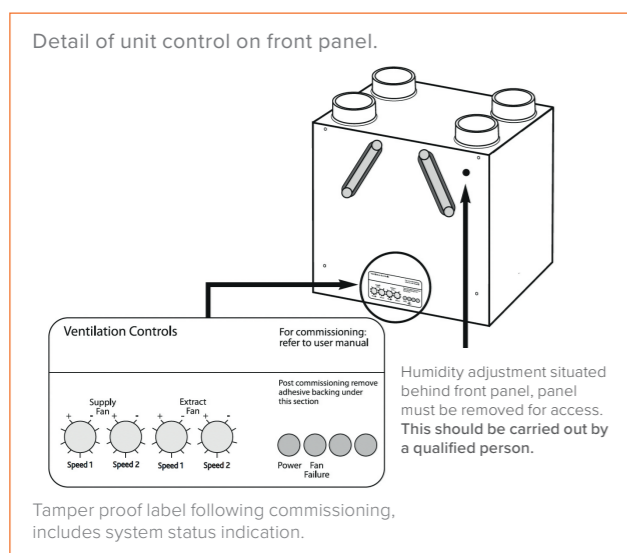

SW Model

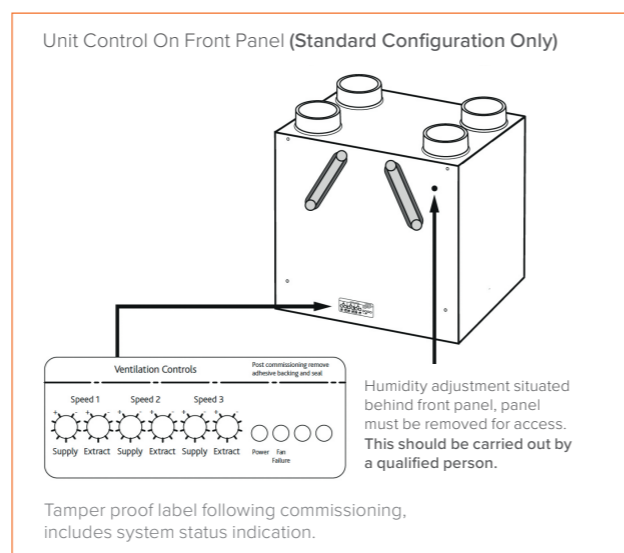

Handing Information

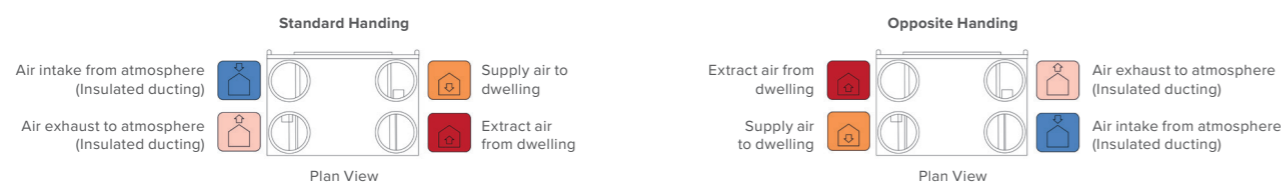

Technical – MRXBOXAB-ECO3B-1Z

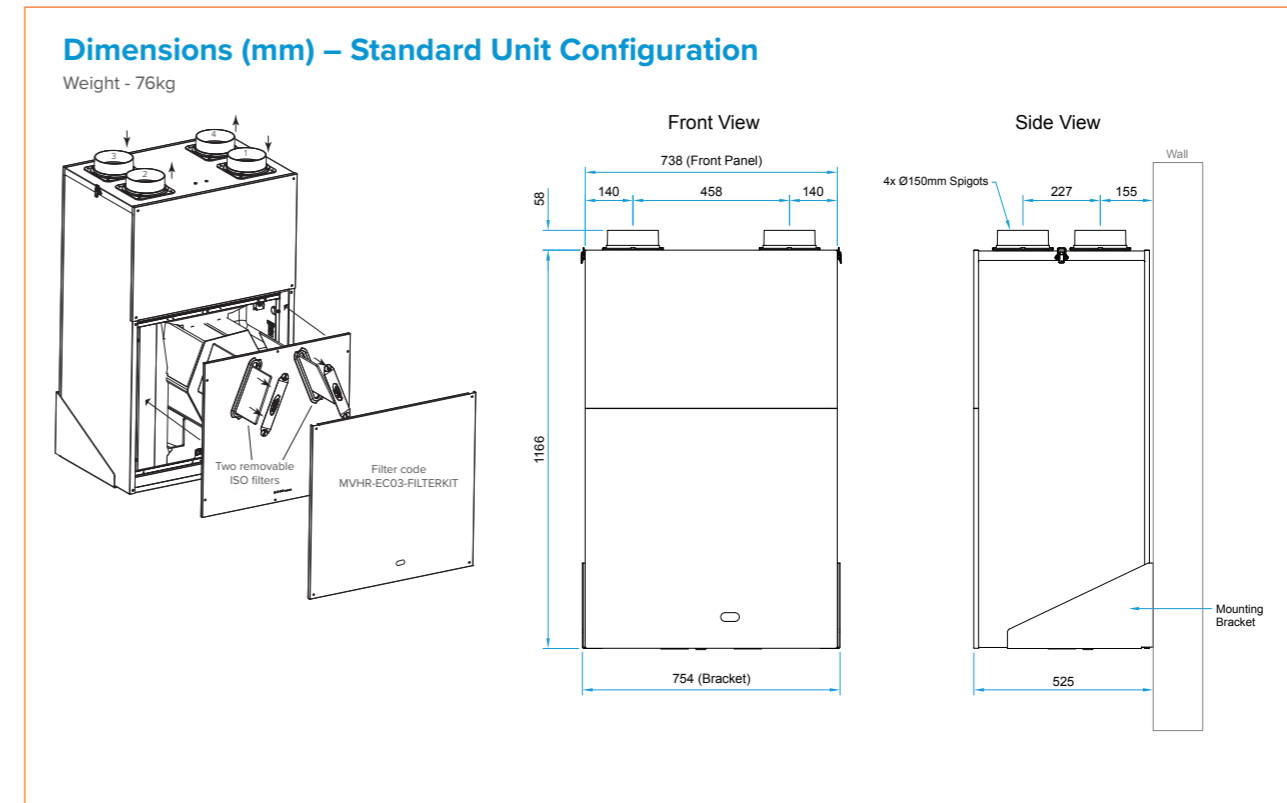

Ancillaries

MRXBOXAB-ECO3B-1Z

The MRXBOX-DB3 is fitted on top of the MRXBOXAB-ECO3B-1Z before installation and offers a neat arrangement by directly distributing the initial ducting. It further benefits this MVHR system by reducing any in-line noise breakout, therefore, improving this acoustic solution.

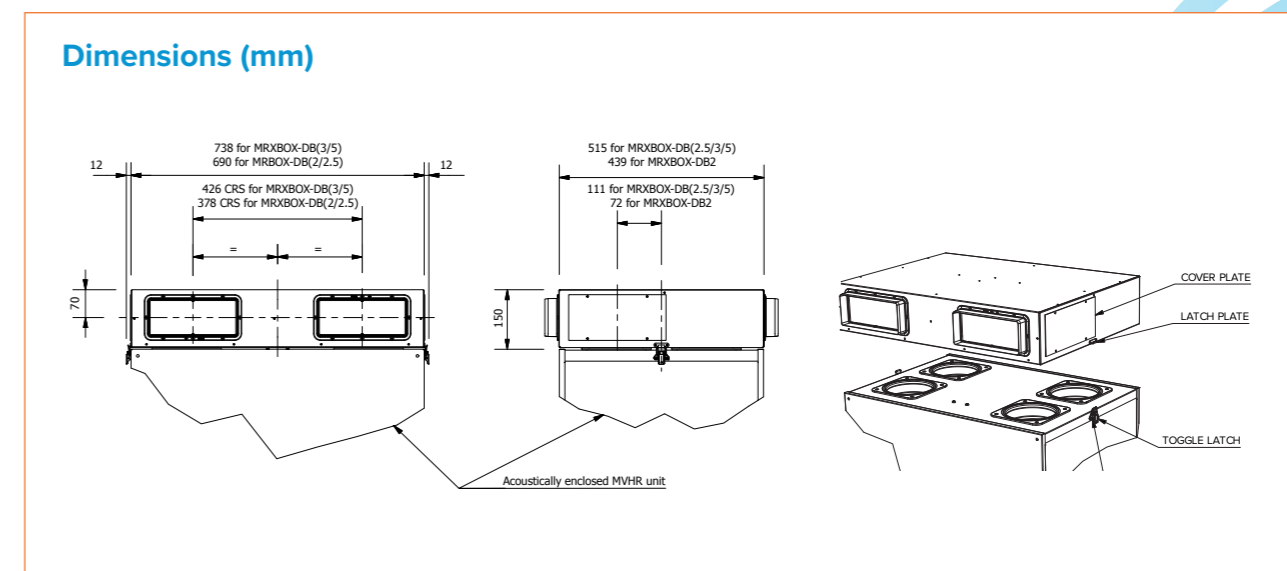

Wiring – MRXBOXAB-ECO3B-1Z

Unit Serving Kitchen & Bathroom

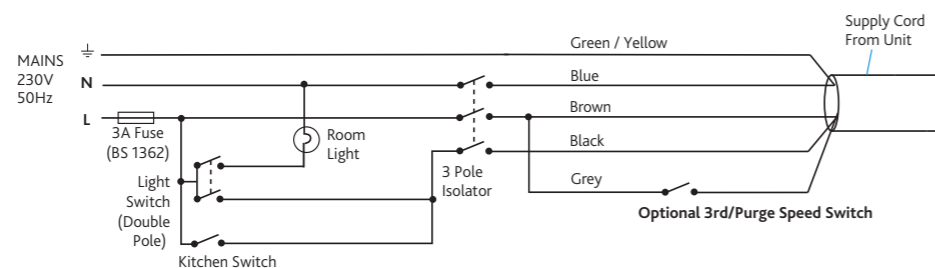

Unit Serving Kitchen & Two Bathrooms

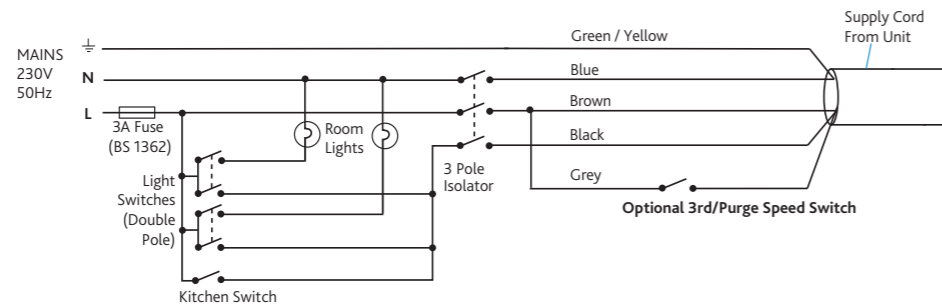

Summer/Winter Switch



Volt free Summer / Winter Switch (supplied with unit)
Polarity is inconsequential
Warning! - Do not connect to mains!

Electrical Details

Please note: the electrical connection of the unit must be carried out by a qualified electrician.

The unit is supplied with a flexible cord for connection to the mains supply. NOTE: This unit must be earthed.

The mains power supply cable should be connected to a fixed wiring installation, via a fused isolator, in accordance with current IEE wiring regulations.

Specification

MRXBOXAB-ECO3B-1Z

SPECIFICATION

The unit shall be fully insulated providing excellent thermal and acoustic characteristics and shall be complete with a multi plate counter flow high efficiency heat exchanger block, with a thermal efficiency of up to 95%. The heat exchanger shall be protected by ISO Coarse filters on fresh air inlet and system extract. The heat exchanger and filters shall be accessible via the front access panel, enabling quick and easy maintenance. The unit shall have low energy, high efficiency EC fan/motor assemblies with sealed for life bearings, the impellers shall be backward curved centrifugal type. The motors shall be suitable of an ambient temperature of 40°C. The unit shall be supplied complete with a condensate drip tray and 21.5mm drain connection.

The unit shall be suitable for 150mm diameter circular ducting. The breakout noise level and power requirements shall be as detailed by the unit manufacturer and in accordance with the ventilation equipment schedule. Units shall be one of MRXBOXAB-ECO3B-1Z or MRXBOXAB-ECO3B-1Z-OH as manufactured by Nuair. The unit shall be provided within a white pre-painted or coated steel acoustic enclosure lined with a minimum of 20mm class '0' acoustic foam insulation to reduce breakout noise.

In-duct noise shall be attenuated on Intake/Exhaust/Supply/Extract by means of a 4-way attenuator mounted within the enclosure, closely coupled directly to the unit. Flexible duct connections shall be within the enclosure, pre-fitted between the attenuator section and the connection spigots on the top face of the enclosure. (Removing the need for flexible duct connectors outside of the unit which may cause breakout). The MVHR unit and attenuator assembly shall be retained within the enclosure on a metal tray supported on turret type anti-vibration mounts of suitable deflection to ensure that vibration is not transmitted to the supporting structure. All operational components of the MVHR unit shall be accessible via the front panel of the enclosure. The enclosure shall be supported on 3mm (minimum) prefabricated steel cantilever wall brackets or other suitable fabricated steel supporting frame.

OPERATION FOR TWO SPEED (STANDARD MODEL)

The supply and extract ventilation unit shall be positioned as indicated on the drawings and shall be in accordance with the particular fan schedule in the specification. This unit is also available in Opposite Hand formatting. The combined supply and extract with heat recovery unit, shall supply filtered fresh air to each of the habitable rooms and vitiated air shall be extracted from the wet areas e.g. bathroom, en-suite, w.c, kitchen, utility rooms, etc. The supply air shall be pre-heated by the warm extract air via the integrated counter-flow heat exchanger element. The extracted air shall also be filtered before it reaches the heat exchanger block. The ventilation unit shall vary its speed and, therefore, the ventilation rate, as it receives signals from one of the following:

- Switched live signal from light/remote switches/remote switch/humidistat switch.

When signals are received, the fan shall alter its speed to adjustable, normal and boost rates. The unit shall have the facility to commission the supply and extract fans independently on minimum speed (continuous background ventilation), and boost speed, via inbuilt minimum and maximum speed adjustment. The fans shall have infinitely variable speed control.

INTEGRAL AUTOMATIC SUMMER BYPASS

(MRXBOXAB-ECO3B-1Z & MRXBOXAB-ECO3B-1Z-OH)

Including automatic Summer Bypass where intake and return air temperatures shall be measured so that supply air temperatures can be maximised during winter months and minimised as external ambient temperature rises. The Summer Bypass damper shall be opened by a wax actuator. Supply and Extract air shall be filtered irrespective of the bypass setting (open or closed).

INTEGRAL HUMIDITY SENSOR

The integral humidity sensor incorporated within the extract fan chamber will automatically boost both the extract and supply fan, to the commissioned boost speed, when the humidity level exceeds that set by the front panel mounted adjustment potentiometer.

SUMMER/WINTER (SW) SWITCH THIRD SPEED

The unit shall feature volt-free connections for a positional switch controlling the bypass logic profile. Summer setting shall target under 20 degrees C internal dwelling temperature. Winter setting shall ensure heat recovery at all times. Temperature control logic shall be factory pre-set and require no on-site programming. The unit shall feature 3 commissionable speeds for both supply and extract. It shall be possible to enable the unit to its 3rd speed by means of a switch or a programmable thermostat with occupant override CM-THERM-CONTROL. The 3rd speed (overheating) shall be inhibited when outside air temperature exceeds inside temperature and bypass closes so that extracted air cools incoming fresh air.

CONTROL OPTIONS

All versions are built in with the following functions integrally mounted within the fan unit on a purpose made PCB, all such components pre-wired and factory fitted by the manufacturer:

- Independent control of background supply and extract flow rates.
- Independent control of boost speed supply and extract flow rates.
- Integral S/L terminal for boost from remote switch, e.g. light switch, kitchen boost switch.
- Integral heat exchanger frost protection.
- Discreet daily run monitor.
- Integral humidistat. (MRXBOXAB-ECO3B-1Z & MRXBOXAB-ECO3B-1Z-OH)

The unit comes with 2 years warranty (including parts and labour).

ALL ROUND MVHR SOLUTIONS

MRXBOXAB-ECO4

The MRXBOXAB-ECO4 is a wall mounted MVHR unit with 100% automatic bypass and integral humidistat, as listed on the SAP Product Characteristics Database (PCDB).

Owing to its intelligent and smart design, there will be no reduction in airflow when operating in bypass mode, resulting in balanced performance. The unit is designed to provide optimised balanced (supply and extract) mechanical ventilation with heat recovery.

The two airflows pass through the heat exchanger where up to 95% of the heat from the extract air is transferred into the supply air before supplying into the habitable rooms, creating comfortable and well-ventilated homes. The two independent fans have infinite variable speed controls for background and boost ventilation rates.

The ECO4 has a Summer Bypass function which automatically activates in warmer months to ensure the property is well-ventilated and comfort levels are maintained in the home by continuously drawing in fresh



filtered air into the habitable rooms. The unit is compact enough to go into a cupboard space, as well as being powerful enough to ventilate the kitchen and up to 6 wet rooms.

Units are available as SW versions with a third controllable speed for Approved Document F&O purge rates and additional SW switch to select between seasonal bypass logic profiles.

Opposite Handed (OH) configuration available.

Installation Features:



Performance

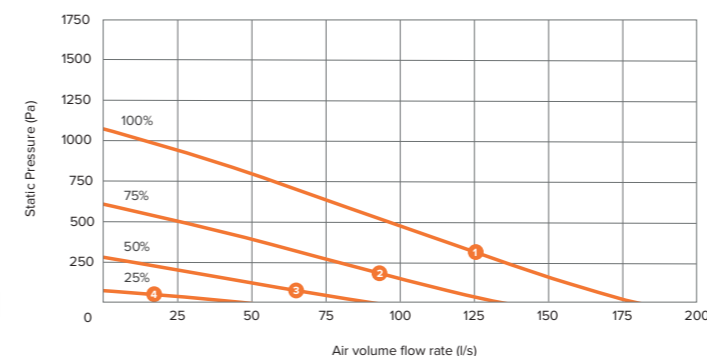

MRXBOXAB-ECO4

Wall mounted unit with 100% bypass and integral humidistat.

MRXBOXAB-ECO4-OH

Opposite Handed configuration wall mounted unit with 100% bypass and integral humidistat.

SUMMER/WINTER SWITCH ONLY (SW)

Units are available as SW versions with a third controllable speed and a Summer/Winter switch, allowing selection of seasonal bypass logic profiles.

Electrical & Sound

ECO4 Sound Data											
Curve	Maximum power consumption (Watts)		Sound Power Levels dB re 1pW (Frequency Hz)								dBA @3m
			63	125	250	500	1k	2k	4k	8k	
1	348	Open inlet	61	56	55	65	54	48	40	33	
		Open outlet	64	65	65	78	66	63	58	55	
		Breakout	67	63	61	64	50	42	35	27	44
2	148	Open inlet	51	54	55	56	48	43	33	25	
		Open outlet	59	64	64	70	60	58	52	47	
		Breakout	61	61	60	59	46	38	30	20	40
3	45	Open inlet	44	47	44	42	36	31	18	<16	
		Open outlet	51	58	56	54	48	46	35	28	
		Breakout	49	55	52	43	35	28	<16	<16	28
4	10	Open inlet	39	36	29	24	20	<16	<16	<16	
		Open outlet	45	44	36	34	28	<16	<16	<16	
		Breakout	40	42	35	24	21	<16	<16	<16	<16

The maximum power consumption shown above (Watts) is consumed on units running continuously, not taking into account any heat recovery saving and based on SAP Product Characteristics Database (PCDB) testing. The breakout case-radiated dBA values are given for Hemispherical free field radiation at 3m – to obtain the Spherical radiated data, subtract 3 dBA.

Please note: Sound data is provided at a particular duty point for 25%, 50%, 75% and 100%. For accurate sound data at a specific speed duty, please use Nuair's fan selector or call the office on 029 2085 8500.

SAP/PCDB Data

Product Code	MRXBOXAB-ECO4		
SAP Identifier	MRXBOXAB-ECO4		
Application	Specific Fan Power (W/l/s)	Heat Exchange Efficiency	Energy Saving Trust Best Practice Compliant
Kitchen + 1 Wet Room	0.62	94%	Yes
Kitchen + 2 Wet Rooms	0.62	93%	Yes
Kitchen + 3 Wet Rooms	0.66	93%	Yes
Kitchen + 4 Wet Rooms	0.79	92%	Yes
Kitchen + 5 Wet Rooms	0.94	91%	Yes

Standard Model

Detail of unit control on front panel.

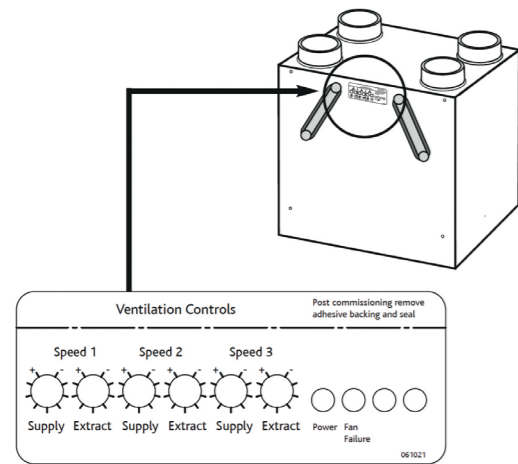

Tamper proof label following commissioning, includes system status indication.

SW Model

Detail of unit control on front panel.

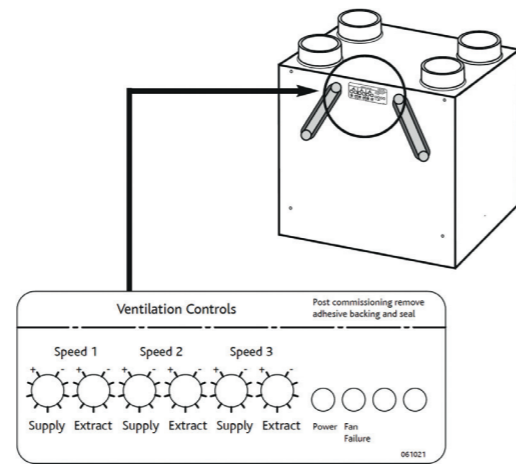

Tamper proof label following commissioning, includes system status indication.

Handing Information

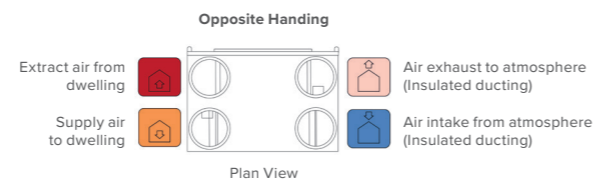
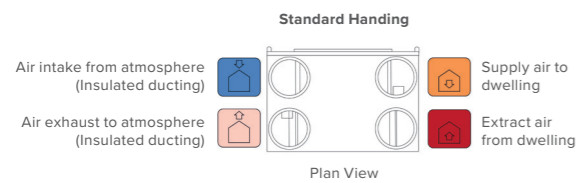

Technical – MRXBOXAB-ECO4

Dimensions (mm) – Standard Unit Configuration

Weight - 44kg

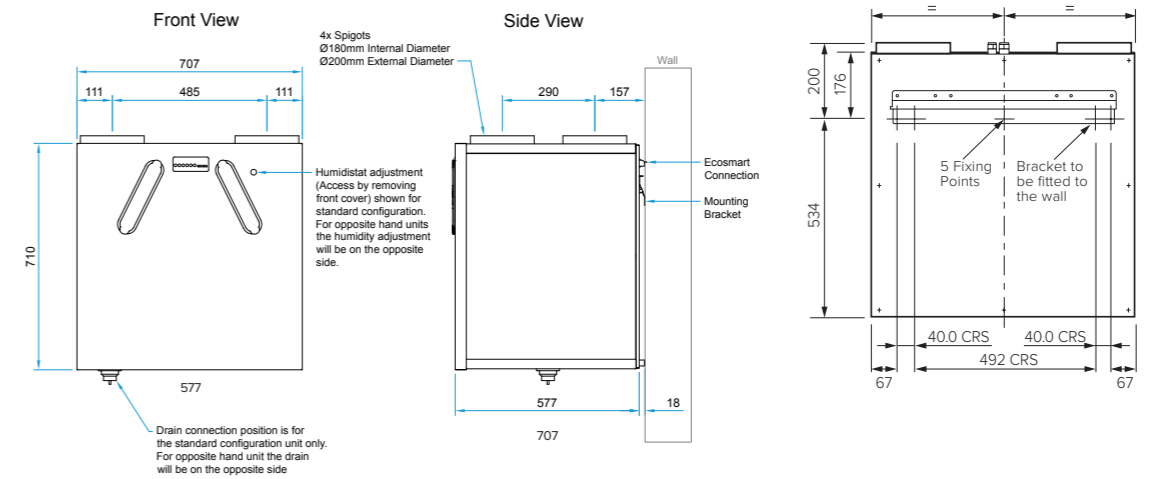

Wiring – MRXBOXAB-ECO4

Unit Serving Kitchen & Bathroom

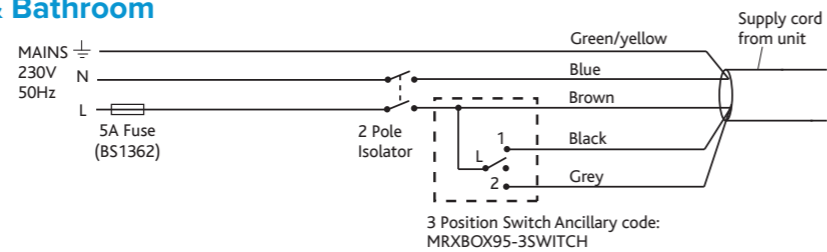

Unit Serving One Bathroom

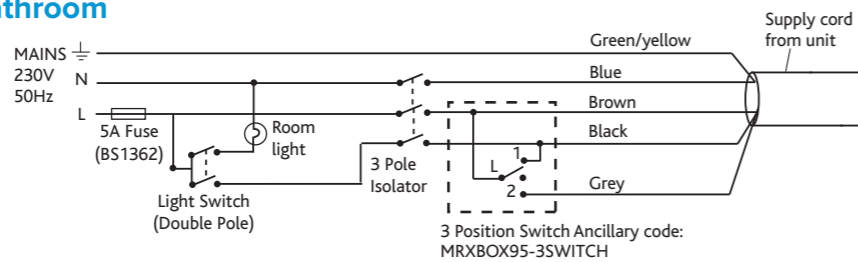

Unit Serving Two Bathrooms

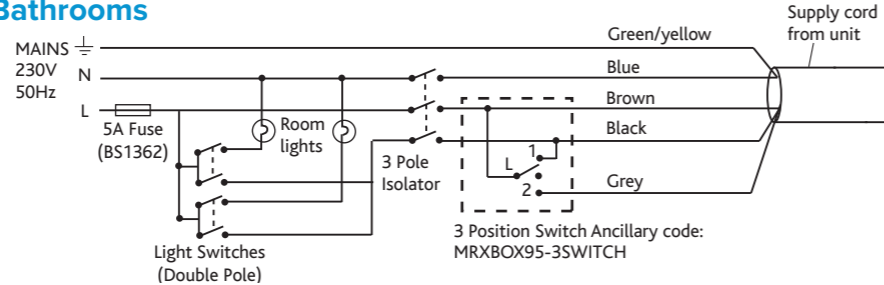

Summer/Winter Switch

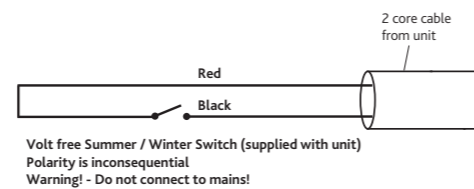

Electrical Details

Please note: the electrical connection of the unit must be carried out by a qualified electrician.

The unit is supplied with a flexible cord for connection to the mains supply. NOTE: This unit must be earthed.

The mains power supply cable should be connected to a fixed wiring installation, via a fused isolator, in accordance with current IEE wiring regulations.

Specification

MRXBOXAB-ECO4

SPECIFICATION

The unit shall be fully insulated providing excellent thermal and acoustic characteristics and shall be complete with a multiplate, counter-flow, high-efficiency heat exchanger block with an efficiency of up to 95%. The heat exchanger shall be protected by ISO Coarse filters on fresh air inlet and system extract. The heat exchanger and filters shall be accessible via the front access panel, enabling quick and easy maintenance. The unit shall have low energy, high-efficiency EC fan/motor assemblies with sealed for life bearings, the impellers shall be backward curved centrifugal type. The motors shall be suitable for an ambient temperature of 40°C. The unit shall be supplied complete with a condensate drip tray and 32mm drain connection. The unit shall be suitable for 200mm diameter circular ducting. Note: The unit is also available in Opposite Handed format, refer to spigot configuration for set up. The breakout noise level and power requirements shall be as detailed by the unit manufacturer and in accordance with the ventilation equipment schedule. The unit shall be MRXBOXAB-ECO4 as manufactured by Nuair and shall be listed on the SAP PCDB. MRXBOXAB-ECO4-OH is an Opposite Handed assembly compliant as per standard handed versions listed in SAP PCDB.

OPERATION FOR TWO SPEED (STANDARD MODEL)

The supply and extract ventilation unit shall be positioned as indicated on the drawings and shall be in accordance with the particular fan schedule in the specification. The combined supply and extract with heat recovery unit shall supply filtered fresh air to each of the habitable rooms and moisture-laden air shall be extracted from the wet areas e.g. bathroom, en-suite, w.c, kitchen, utility rooms, etc. The supply air shall be pre-heated by the warm extract air via the integrated counter-flow heat exchanger element. The extracted air shall also be filtered before it reaches the heat exchanger block. The ventilation unit shall vary its speed and, therefore, the ventilation rate, as it receives signals from one of the following:

- Switched live signal from light/remote switches/remote switch/humidistat switch.

When signals are received, the fan shall alter its speed to adjustable, normal and boost rates. The unit shall have the facility to commission the supply and extract fans independently on minimum speed (continuous background ventilation) and boost speed via inbuilt minimum and maximum speed adjustment. The fans shall have infinitely variable speed control.

INTEGRAL AUTOMATIC HX BYPASS WITH NO REDUCTION IN AIRFLOW

The bypass damper shall open automatically via a wax actuator allowing the air to bypass the heat exchanger to deliver fresh filtered air during the warmer months. Under normal operation, the automatic bypass diverts 100% airflow around the heat exchanger with no reduction in airflow, as independently tested by the BRE.

INTEGRAL HUMIDITY SENSOR

The integral humidity sensor incorporated within the extract fan chamber will automatically boost both the extract and supply fan, to the commissioned boost speed, when the humidity level exceeds that set by the front panel mounted adjustment potentiometer.

OPTIONAL REMOTE SWITCH (MRXBOX95-3SWITCH)

The unit shall have the facility to wire a three position remote switch to a suitable location within the property. The switch shall have 3 settings: trickle, boost and Summertime boost facility. The remote switch will act as the master switch and will override all other switches.

SUMMER/WINTER (SW) SWITCH THIRD SPEED

The unit shall feature volt-free connections for a positional switch controlling the bypass logic profile. Summer setting shall target under 20 degrees C internal dwelling temperature. Winter setting shall ensure heat recovery at all times. Temperature control logic shall be factory pre-set and require no on-site programming. The unit shall feature 3 commissionable speeds for both supply and extract. It shall be possible to enable the unit to its 3rd speed by means of a switch or a programmable thermostat with occupant override CM-THERM-CONTROL. The 3rd speed (overheating) shall be inhibited when outside air temperature exceeds inside temperature and bypass closes, so that extracted air cools incoming fresh air.

CONTROL OPTIONS

All versions are built in with the following functions integrally mounted within the fan unit on a purpose made PCB, all such components are pre-wired and factory fitted by the manufacturer:

- Independent control of background supply and extract flow rates.
- Independent control of boost speed supply and extract flow rates.
- Integral heat exchanger frost protection.
- Run/fault indication to external control systems/BMS via ES-VF.
- Integral S/L terminal for boost from remote switch, e.g. light switch.
- Additional S/L terminal for 100% boost speed from remote switch, e.g. plate switch.
- Discreet daily run monitor.
- Indication and controls – The unit shall have clear LED visual indication for maintenance, servicing and operation mode, i.e. HX bypass, frost protection.

The unit comes with 2 years warranty (including parts and labour).

ACOUSTIC SOLUTIONS

MRXBOXAB-ECO4

Nuaire's First Fix and Acoustic Solutions are designed to not only reduce noise but to improve the installation when wall or cupboard mounting the MRXBOXAB-ECO4 unit.

Offering the only complete MVHR acoustic and first fix solution to overcome both noise and ease of installation. The acoustic solution address ducting noise and is an aesthetically pleasing design for cupboard installation.

Opposite Handed (OH) units available.

- Section 1** - First fix plenum chamber
- Section 2** - Silencer box has four airflow chambers, reducing induct noise
- Section 3** - MVHR unit

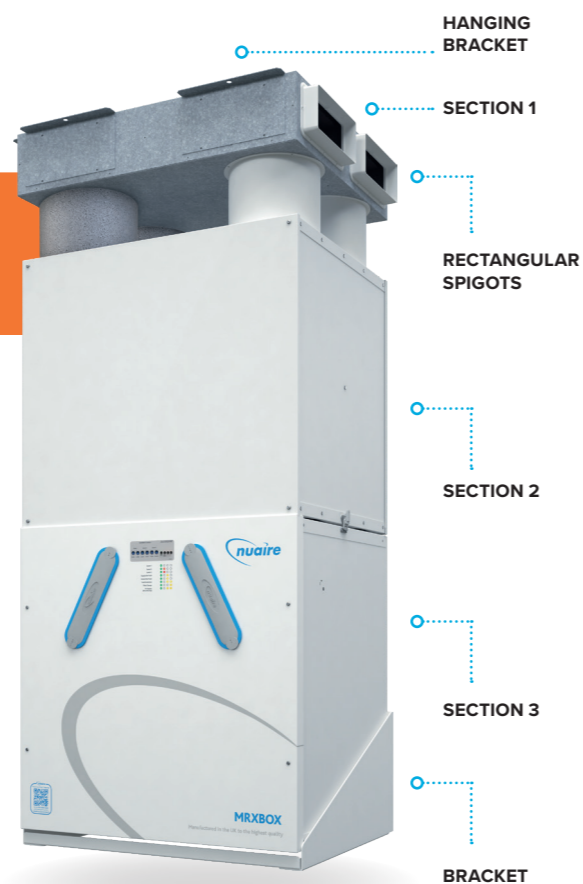

Technical Data

Dimensions (mm) for ECO4 unit

Weight - 44kg

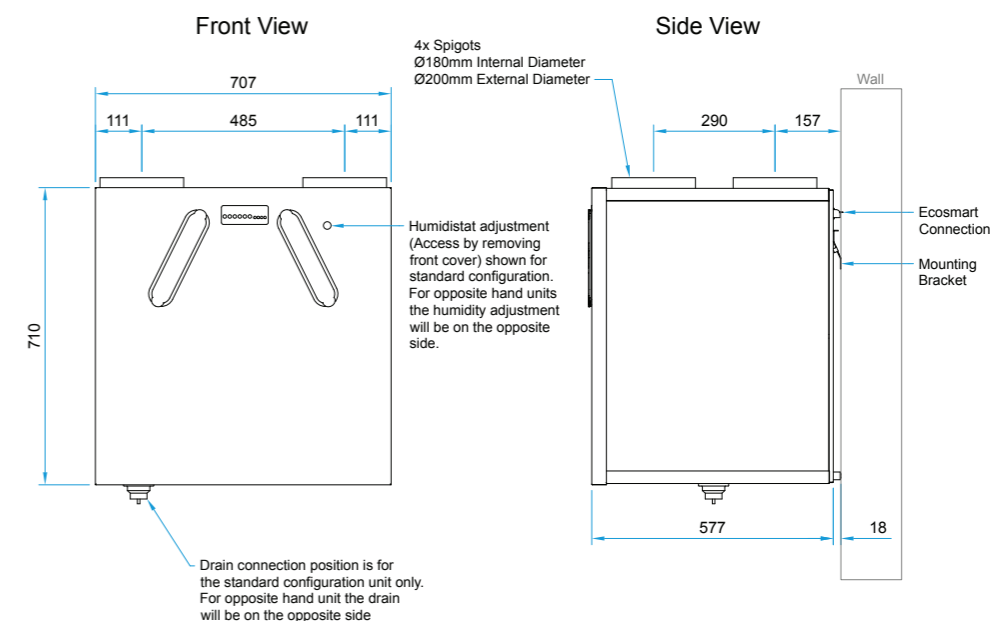

Installation Features:

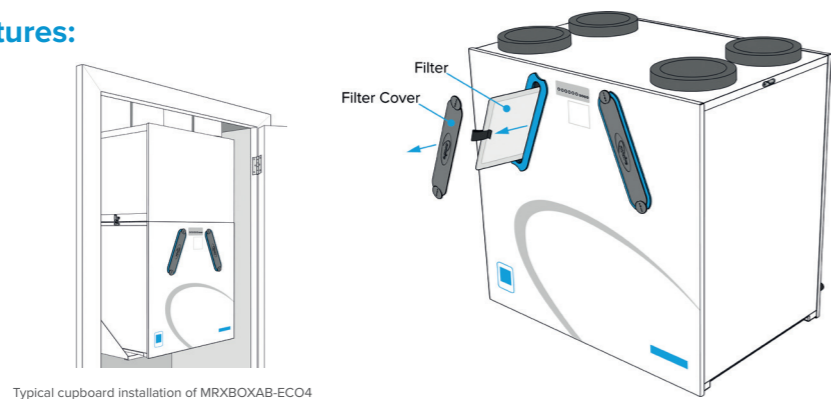

Acoustic data for MRXBOXAB-ECO4 with Silencer and/or First Fix box

Ancillary Sound Data								
MRXBOX-SIL4	63	125	250	500	1K	2K	4K	8K
SUPPLY/DISCHARGE	-11	-10	-13	-14	-22	-33	-35	-29
INTAKE/EXTRACT	-3	-5	-9	-14	-16	-16	-10	-8
MRXBOX-FF4								
SUPPLY/DISCHARGE	-2	-9	-9	-13	-3	0	0	0
INTAKE/EXTRACT	-3	-8	-8	-11	-3	0	0	0
MRXBOX-SIL4+ FF4								
SUPPLY/DISCHARGE	-13	-18	-22	-28	-26	-33	-34	-36
INTAKE/EXTRACT	-5	-10	-15	-23	-21	-21	-17	-16

ACOUSTIC ENCLOSURE

MRXBOXAB-ECO4-AE

The AE is a wall mounted MVHR unit with a factory fitted acoustic enclosure. Flexible duct connections and anti-vibration mounts are incorporated within the AE, providing vibration isolation from the supporting structure and significantly reducing case radiated noise, even at high running speeds.



The unit is equipped to commission the supply and extract fans independently on both minimum and maximum speeds, with the heat exchange blocks being able to recover up to 95% of the wasted heat that has been extracted from the 'wet areas' within the property and at the same time drawing in fresh supply air from outside.

Units are available as SW versions with a third controllable speed for Approved Document F&O purge rates and additional SW switch to select between seasonal bypass logic profiles.

Opposite Handed (OH) configuration available.

The two independent fans have infinite variable speed controls for background and boost ventilation rates. Nuaire guarantee that 100% design airflow rate is maintained in bypass operation.



Installation Features:



Performance

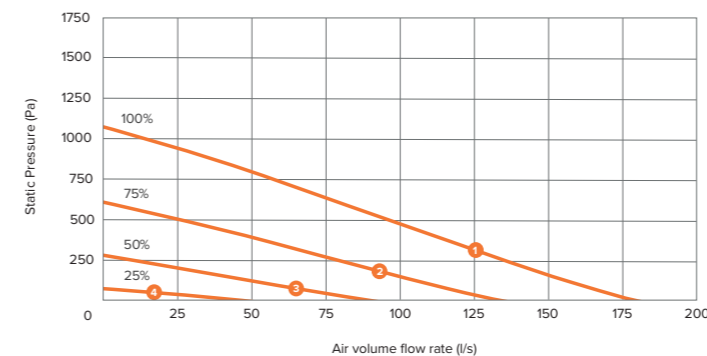

MRXBOXAB-ECO4-AE

Wall mounted unit with 100% bypass and integral humidistat.

MRXBOXAB-ECO4-AE-OH

Opposite Handed configuration wall mounted unit with 100% bypass and integral humidistat.

SUMMER/WINTER SWITCH ONLY (SW)

Units are available as SW versions with a third controllable speed and a Summer/Winter switch, allowing selection of seasonal bypass logic profiles.

Electrical & Sound

ECO4-AE Sound Data											
Curve	Power consumption (Watts)		Sound Power Levels dB re 1pW (Frequency Hz)								dBA @3m
			63	125	250	500	1k	2k	4k	8k	
1	348	Open inlet	61	56	55	65	54	48	40	33	
		Open outlet	64	65	65	78	66	63	58	55	
		Breakout	65	58	54	48	29	18	<16	<16	31
2	148	Open inlet	51	54	55	56	48	43	33	25	
		Open outlet	59	64	64	70	60	58	52	47	
		Breakout	59	56	53	43	25	<16	<16	<16	29
3	45	Open inlet	44	47	44	42	36	31	18	<16	
		Open outlet	51	58	56	54	48	46	35	28	
		Breakout	47	50	45	27	<16	<16	<16	<16	20
4	10	Open inlet	39	36	29	24	20	<16	<16	<16	
		Open outlet	45	44	36	34	28	<16	<16	<16	
		Breakout	39	38	30	<16	<16	<16	<16	<16	<16

The maximum power consumption shown above (Watts) is consumed on units running continuously, not taking into account any heat recovery saving and based on SAP Product Characteristics Database (PCDB) testing. The breakout case-radiated dBA values are given for Hemispherical free field radiation at 3m – to obtain the Spherical radiated data, subtract 3 dBA.

Please note: Sound data is provided at a particular duty point for 25%, 50%, 75% and 100%. For accurate sound data at a specific speed duty, please use Nuaire's fan selector or call the office on 029 2085 8500.

SAP/PCDB Data

Product Code	MRXBOXAB-ECO4-AE		
SAP Identifier	MRXBOXAB-ECO4		
Application	Specific Fan Power (W/l/s)	Heat Exchange Efficiency	Energy Saving Trust Best Practice Compliant
Kitchen + 1 Wet Room	0.62	94%	Yes
Kitchen + 2 Wet Rooms	0.62	93%	Yes
Kitchen + 3 Wet Rooms	0.66	93%	Yes
Kitchen + 4 Wet Rooms	0.79	92%	Yes
Kitchen + 5 Wet Rooms	0.94	91%	Yes

Standard Model

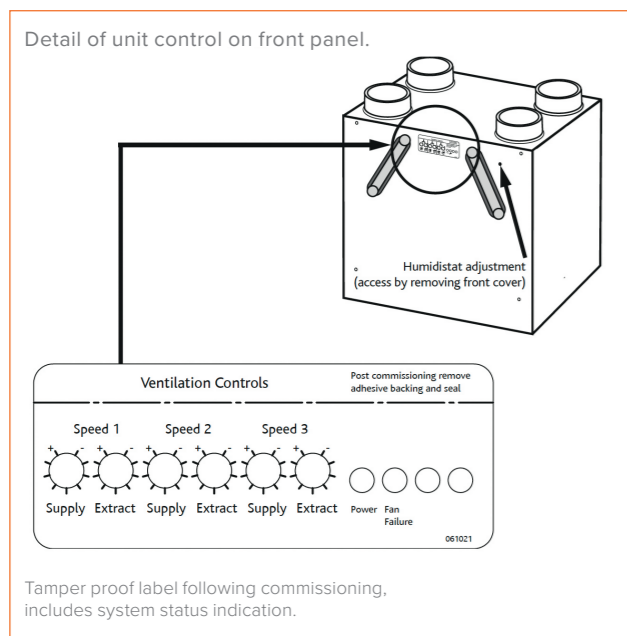

SW Model

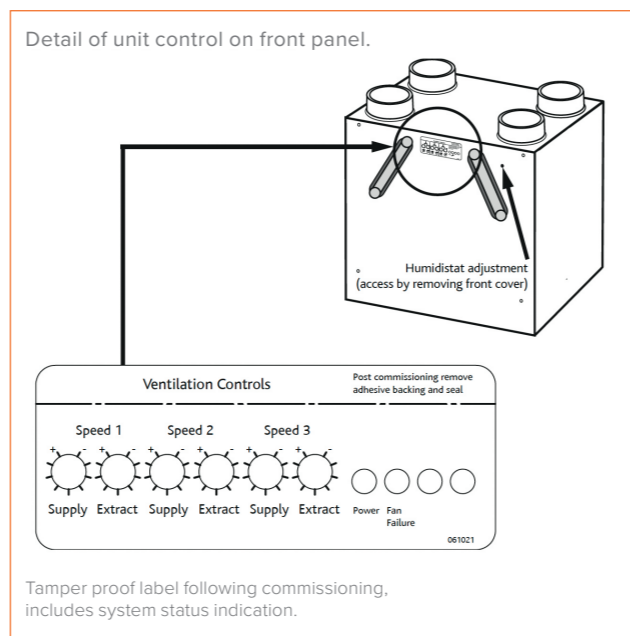

Handing Information

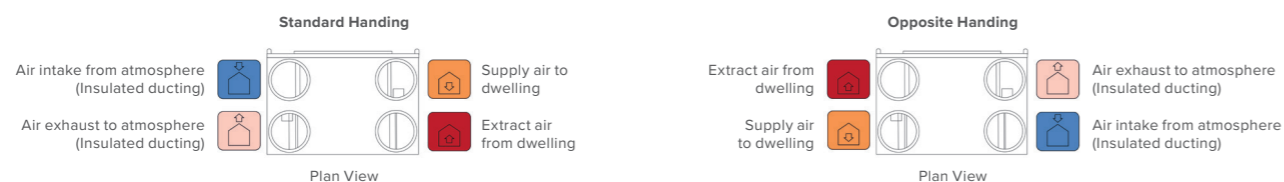

Technical – MRXBOXAB-ECO4-AE

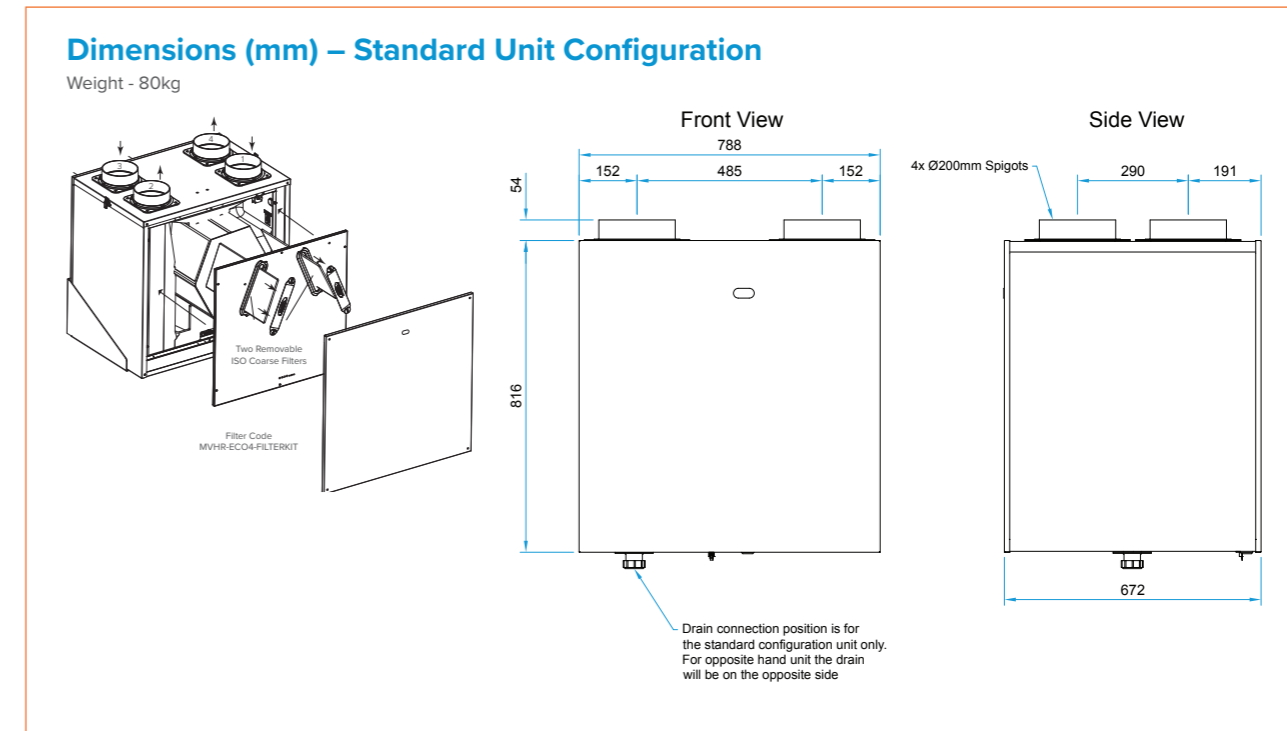

Ancillaries

MRXBOXAB-ECO4-AE

The MRXBOX-DB4 is fitted on top of the MRXBOXAB-ECO4-AE before installation and offers a neat arrangement by directly distributing the initial ducting. It further benefits this MVHR system by reducing any in-line noise breakout, therefore, improving this acoustic solution.

Dimensions (mm)

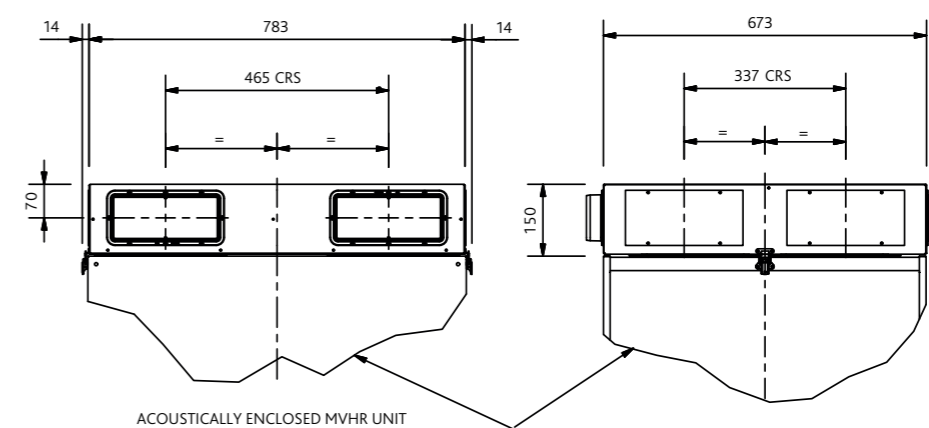

Wiring – MRXBOX-ECO4-AE

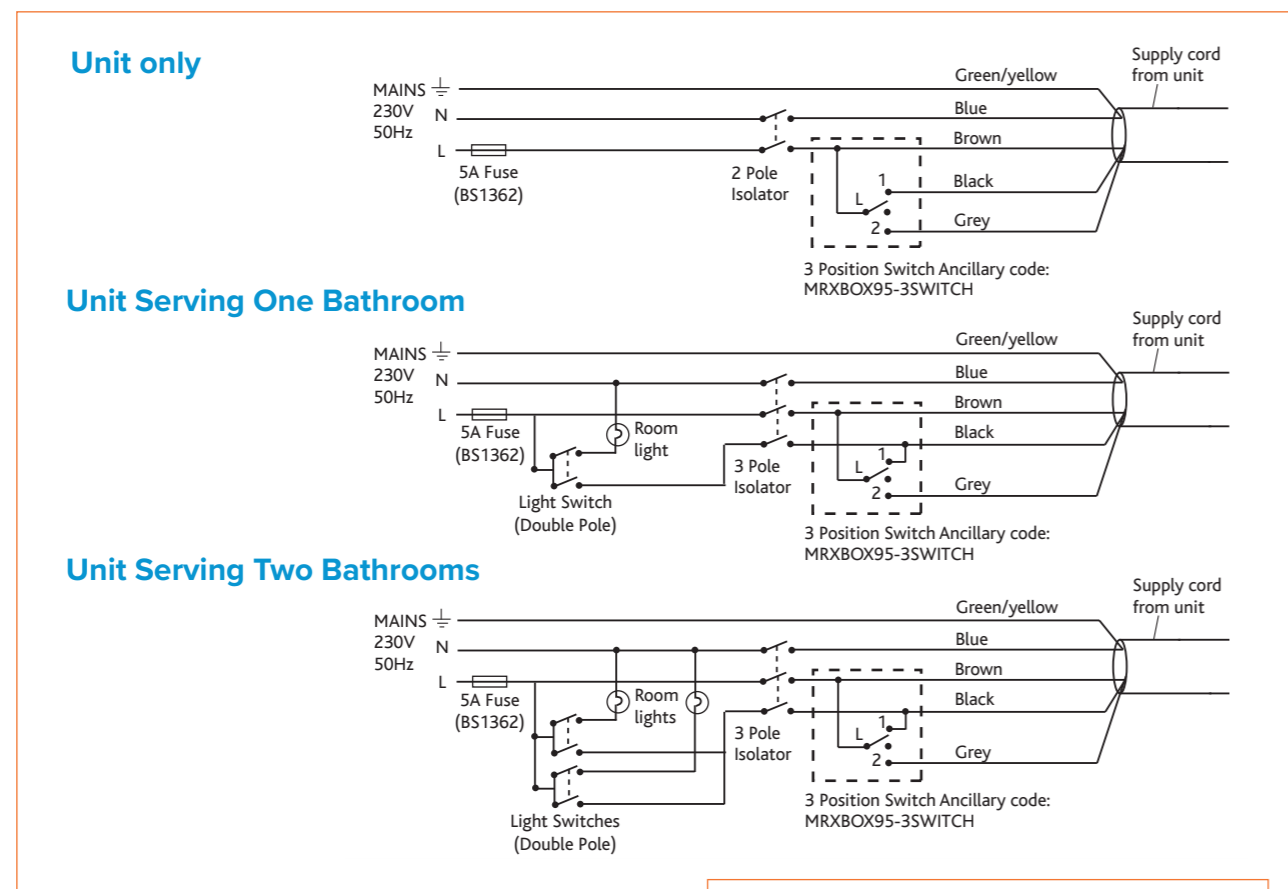

Electrical Details

Please note: the electrical connection of the unit must be carried out by a qualified electrician.

The unit is supplied with a flexible cord for connection to the mains supply. NOTE: This unit must be earthed.

The mains power supply cable should be connected to a fixed wiring installation, via a fused isolator, in accordance with current IEE wiring regulations.

Summer/Winter Switch

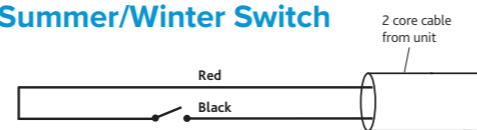

Volt free Summer / Winter Switch (supplied with unit)
Polarity is inconsequential
Warning! - Do not connect to mains!

Specification

MRXBOXAB-ECO4-AE

SPECIFICATION

The unit shall be fully insulated providing excellent thermal and acoustic characteristics and shall be complete with a multi plate counter flow high efficiency heat exchanger block, with a thermal efficiency of up to 95%. The heat exchanger shall be protected by ISO Coarse filters on fresh air inlet and system extract. The heat exchanger and filters shall be accessible via the front access panel, enabling quick and easy maintenance.

The unit shall have low energy, high efficiency EC fan/motor assemblies with sealed for life bearings, the impellers shall be backward curved centrifugal type. The motors shall be suitable of an ambient temperature of 40°C. The unit shall be supplied complete with a condensate drip tray and 21.5mm drain connection.

The unit shall be suitable for 200mm diameter circular ducting. The breakout noise level and power requirements shall be as detailed by the unit manufacturer and in accordance with the ventilation equipment schedule. Units shall be one of MRXBOXAB-ECO4-AE and MRXBOXAB-ECO4-AE-OH as manufactured by Nuair.

The unit shall be provided within a white pre-painted or coated steel acoustic enclosure lined with a minimum of 20mm class '0' acoustic foam insulation to reduce breakout noise. Flexible duct connections shall be within the enclosure, pre-fitted between the MVHR unit and the connection spigots on the top face of the enclosure. (Removing the need for flexible duct connectors outside of the unit which may cause breakout).

The MVHR unit shall be retained within the enclosure on a metal tray supported on turret type anti-vibration mounts of suitable deflection to ensure that vibration is not transmitted to the supporting structure.

OPERATION FOR TWO SPEED (STANDARD MODEL)

The supply and extract ventilation unit shall be positioned as indicated on the drawings and shall be in accordance with the particular fan schedule in the specification. This unit is also available in Opposite Hand formatting.

The combined supply and extract with heat recovery unit, shall supply filtered fresh air to each of the habitable rooms and vitiated air shall be extracted from the wet areas e.g. bathroom, en-suite, w.c, kitchen, utility rooms, etc. The supply air shall be pre-heated by the warm extract air via the integrated counter-flow heat exchanger element. The extracted air shall also be filtered before it reaches the heat exchanger block.

The ventilation unit shall vary its speed and, therefore, the ventilation rate, as it receives signals from one of the following:

- Switched live signal from light/remote switches/remote switch/humidistat switch.

When signals are received, the fan shall alter its speed to adjustable, normal and boost rates. The unit shall have the facility to commission the supply and extract fans independently on minimum speed (continuous background ventilation), and boost speed, via an inbuilt minimum and maximum speed adjustment. The fans shall have infinite variable speed controls.

INTEGRAL AUTOMATIC SUMMER BYPASS

Including Automatic Summer Bypass where intake and return air temperatures shall be measured so that supply air temperatures can be maximised during winter months and minimised as external ambient temperatures rise. The Summer Bypass damper shall be opened by a wax actuator. Supply and Extract air shall be filtered irrespective of the bypass setting (open or closed).

INTEGRAL HUMIDITY SENSOR

The integral humidity sensor incorporated within the extract fan chamber will automatically boost both the extract and supply fan, to the commissioned boost speed, when the humidity level exceeds that set by the front panel mounted adjustment potentiometer.

SUMMER/WINTER (SW) SWITCH THIRD SPEED

The unit shall feature volt-free connections for a positional switch controlling the bypass logic profile. Summer setting shall target under 20 degrees C internal dwelling temperature. Winter setting shall ensure heat recovery at all times. Temperature control logic shall be factory pre-set and require no on-site programming. The unit shall feature 3 commissionable speeds for both supply and extract. It shall be possible to enable the unit to its 3rd speed by means of a switch or a programmable thermostat with occupant override CM-THERM-CONTROL The 3rd speed (overheating) shall be inhibited when outside air temperature exceeds inside temperature and bypass closes so that extracted air cools incoming fresh air.

CONTROL OPTIONS

All versions are built in with the following functions integrally mounted within the fan unit on a purpose made PCB, all such components prewired and factory fitted by the manufacturer:

- Independent control of background supply and extract flow rates.
- Independent control of boost speed supply and extract flow rates.
- Run/fault indication to external control systems/BMS via ES-VF.
- Integral S/L terminal for boost from remote switch, e.g. light switch, kitchen boost switch.
- Integral heat exchanger frost protection.
- Discreet daily run monitor.
- Integral humidistat.

The unit comes with 2 years warranty (including parts and labour).

ALL IN ONE ACOUSTIC SOLUTION

MRXBOXAB-ECO4-1Z

The MRXBOXAB-ECO4-1Z is the all-in-one acoustic enclosure, allowing the MVHR unit and attenuator to be entirely encased.

With an aesthetically pleasing design enclosing the attenuator, flexible duct connections and anti-vibration mounts that would otherwise be visible whilst making a significant reduction in case radiated noise.

The unit is equipped to commission the supply and extract fans independently on both minimum and maximum speeds, with the heat exchange blocks being able to recover up to 95% of the wasted heat that has been extracted from the 'wet areas' within the property and at the same time drawing in fresh supply air from outside. The 1Z model is designed to provide optimised balanced (supply and extract) mechanical ventilation heat recovery, whilst offering the best all-in-one acoustic solution on the market.

Units are available as SW versions with a third controllable speed for Approved Document F&O purge rates and additional SW switch to select between seasonal bypass logic profiles.

Opposite Handed (OH) configuration available.



Installation Features:



Performance

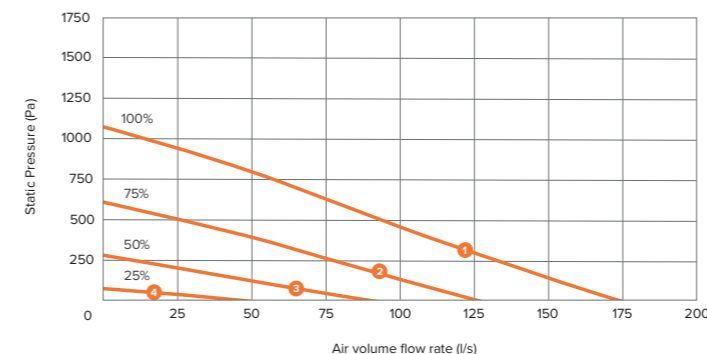

MRXBOXAB-ECO4-1Z

Wall mounted unit with 100% bypass and integral humidistat.

MRXBOXAB-ECO4-1Z-OH

Opposite Handed configuration wall mounted unit with 100% bypass and integral humidistat.

SUMMER/WINTER SWITCH ONLY (SW)

Units are available as SW versions with a third controllable speed and a Summer/Winter switch, allowing selection of seasonal bypass logic profiles.

Electrical & Sound

ECO4-1Z Sound Data											
Curve	Maximum power consumption (Watts)		Sound Power Levels dB re 1pW (Frequency Hz)								dBA @3m
			63	125	250	500	1k	2k	4k	8k	
1	348	Open inlet	58	51	46	51	38	32	30	25	
		Open outlet	53	55	52	62	44	30	23	26	
		Breakout	65	58	54	48	29	18	<16	<16	31
2	148	Open inlet	48	49	46	42	32	27	22	17	
		Open outlet	48	54	51	54	38	25	16	18	
		Breakout	59	56	53	43	25	<16	<16	<16	29
3	45	Open inlet	41	42	34	28	20	<16	<16	<16	
		Open outlet	40	48	43	37	26	<16	<16	<16	
		Breakout	47	49	45	26	<16	<16	<16	<16	20
4	10	Open inlet	37	32	22	<16	<16	<16	<16	<16	
		Open outlet	37	38	27	23	<16	<16	<16	<16	
		Breakout	39	38	30	<16	<16	<16	<16	<16	<16

The maximum power consumption shown above (Watts) is consumed on units running continuously, not taking into account any heat recovery saving and based on SAP Product Characteristics Database (PCDB) testing. The breakout case-radiated dBA values are given for Hemispherical free field radiation at 3m – to obtain the Spherical radiated data, subtract 3 dBA.

Please note: Sound data is provided at a particular duty point for 25%, 50%, 75% and 100%. For accurate sound data at a specific speed duty, please use Nuaire's fan selector or call the office on 029 2085 8500.

SAP/PCDB Data

Product Code	MRXBOXAB-ECO4-1Z		
SAP Identifier	MRXBOXAB-ECO4		
Application	Specific Fan Power (W/l/s)	Heat Exchange Efficiency	Energy Saving Trust Best Practice Compliant
Kitchen + 1 Wet Room	0.62	94%	Yes
Kitchen + 2 Wet Rooms	0.62	93%	Yes
Kitchen + 3 Wet Rooms	0.66	93%	Yes
Kitchen + 4 Wet Rooms	0.79	92%	Yes
Kitchen + 5 Wet Rooms	0.94	91%	Yes

Standard Model

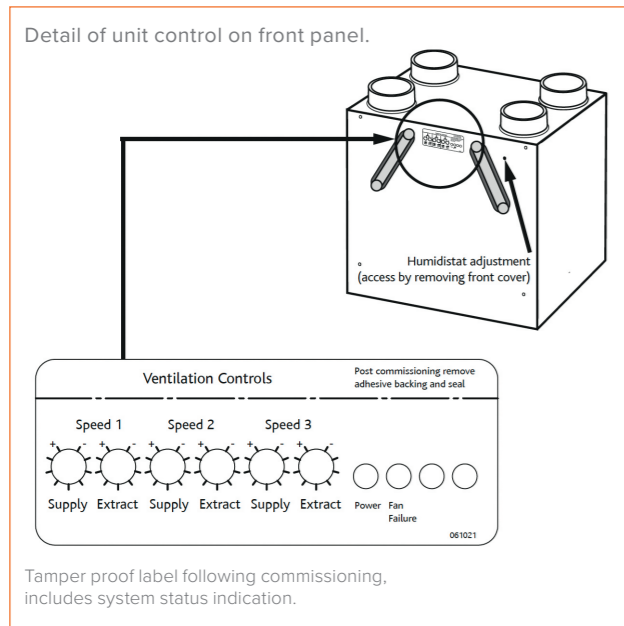

SW Model

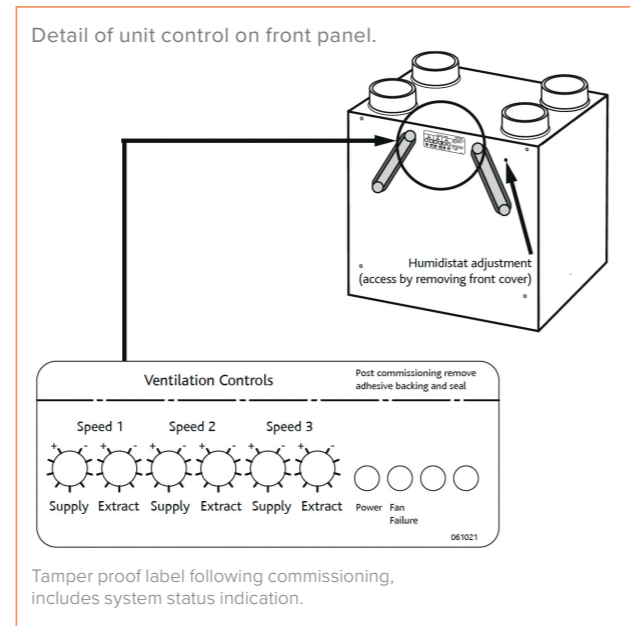

Handing Information

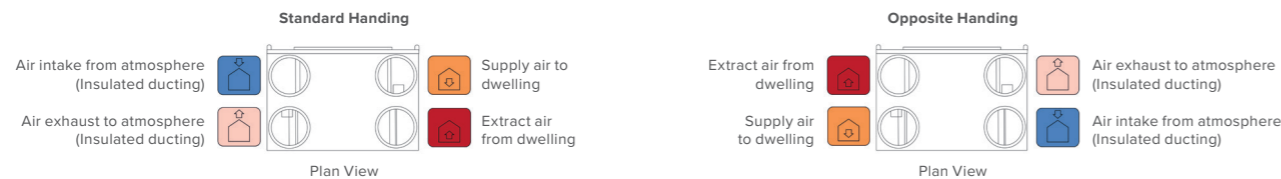

Technical – MRXBOXAB-ECO4-1Z

Dimensions (mm) – Standard Unit Configuration

Weight - 44kg

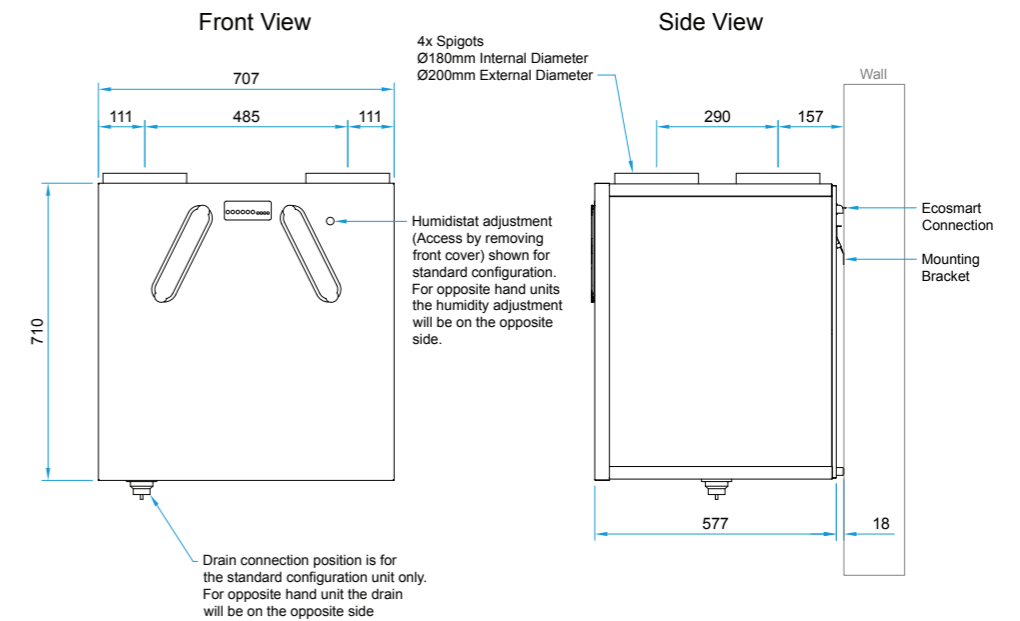

Ancillaries

MRXBOXAB-ECO4-1Z

The MRXBOX-DB4 is fitted on top of the MRXBOXAB-ECO4-1Z before installation and offers a neat arrangement by directly distributing the initial ducting. It further benefits this MVHR system by reducing any in-line noise breakout, therefore, improving this acoustic solution.

Dimensions (mm)

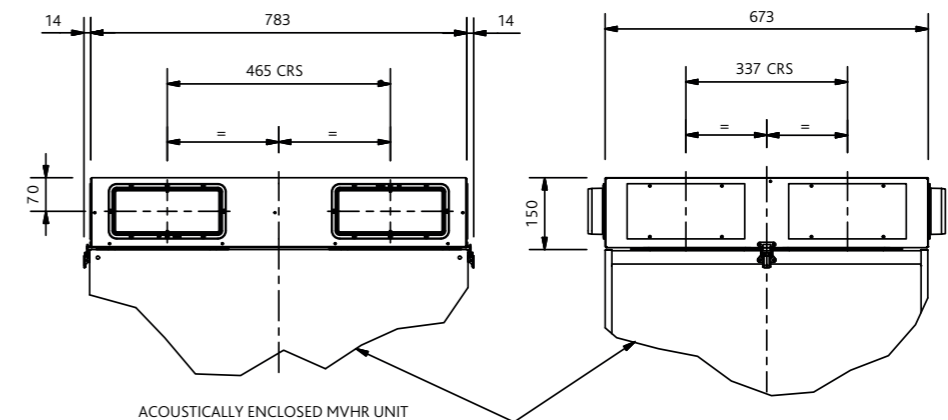

MRXBOXAB-ECO4-1Z

Unit Only

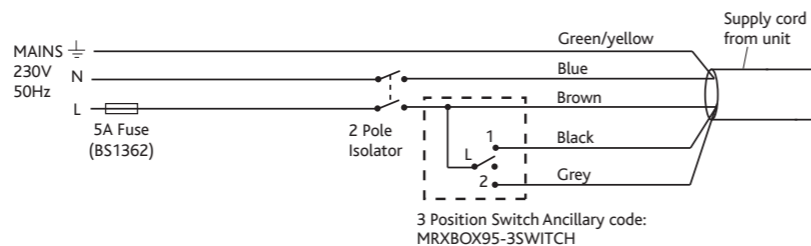

Unit Serving One Bathrooms

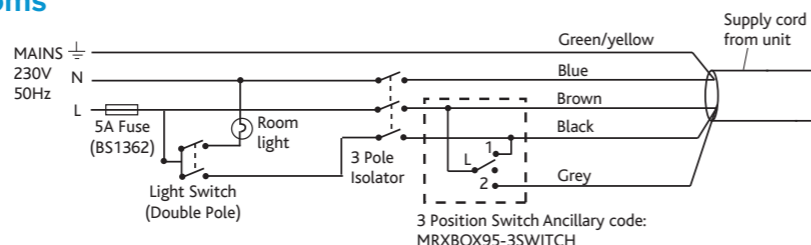

Unit Serving Two Bathrooms

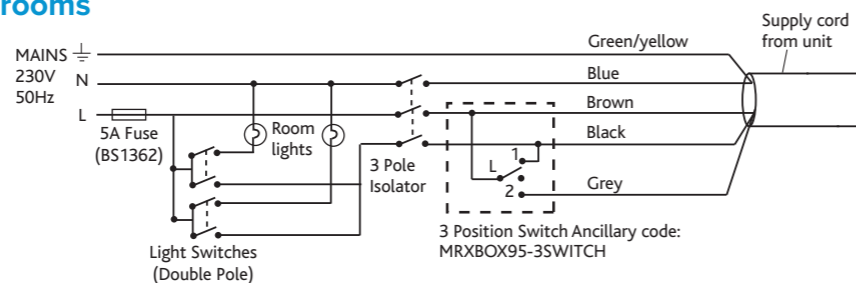

Summer/Winter Switch

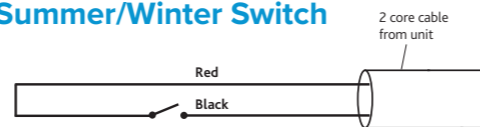

Volt free Summer / Winter Switch (supplied with unit)
Polarity is inconsequential
Warning! - Do not connect to mains!

Electrical Details

Please note: the electrical connection of the unit must be carried out by a qualified electrician.

The unit is supplied with a flexible cord for connection to the mains supply. NOTE: This unit must be earthed.

The mains power supply cable should be connected to a fixed wiring installation, via a fused isolator, in accordance with current IEE wiring regulations.

Specification

MRXBOXAB-ECO4-1Z

SPECIFICATION

The unit shall be fully insulated providing excellent thermal and acoustic characteristics and shall be complete with a multi plate counter flow high efficiency heat exchanger block, with a thermal efficiency of up to 95%.

The heat exchanger shall be protected by ISO Coarse filters on fresh air inlet and system extract. The heat exchanger and filters shall be accessible via the front access panel, enabling quick and easy maintenance. The unit shall have low energy, high efficiency EC fan/motor assemblies with sealed for life bearings, the impellers shall be backward curved centrifugal type. The motors shall be suitable of an ambient temperature of 40°C. The unit shall be supplied complete with a condensate drip tray and 21.5mm drain connection.

The unit shall be suitable for 200mm diameter circular ducting. The breakout noise level and power requirements shall be as detailed by the unit manufacturer and in accordance with the ventilation equipment schedule. Units shall be one of MRXBOXAB-ECO4-1Z and MRXBOXAB-ECO4-1Z-OH as manufactured by Nuair. The unit shall be provided within a white pre-painted or coated steel acoustic enclosure lined with a minimum of 20mm class '0' acoustic foam insulation to reduce breakout noise.

In-duct noise shall be attenuated on Intake/Exhaust/Supply/Extract by means of a 4-way attenuator mounted within the enclosure and close coupled directly to the unit. Flexible duct connections shall be within the enclosure, pre-fitted between the attenuator section and the connection spigots on the top face of the enclosure. (Removing the need for flexible duct connectors outside of the unit which may cause breakout). The MVHR unit and attenuator assembly shall be retained within the enclosure on a metal tray supported on turret type anti-vibration mounts of suitable deflection to ensure that vibration is not transmitted to the supporting structure.

OPERATION FOR TWO SPEED (STANDARD MODEL)

The supply and extract ventilation unit shall be positioned as indicated on the drawings and shall be in accordance with the particular fan schedule in the specification. This unit is also available in Opposite Hand formatting.

The combined supply and extract with heat recovery unit, shall supply filtered fresh air to each of the habitable rooms and vitiated air shall be extracted from the wet areas e.g. bathroom, en-suite, w.c, kitchen, utility rooms, etc. The supply air shall be pre-heated by the warm extract air via the integrated counter-flow heat exchanger element. The extracted air shall also be filtered before it reaches the heat exchanger block. The ventilation unit shall vary its speed and, therefore, the ventilation rate, as it receives signals from one of the following:

- Switched live signal from light/remote switches/remote switch/humidistat switch.

When signals are received, the fan shall alter its speed to adjustable, normal and boost rates. The unit shall have the facility to commission the supply and extract fans independently on minimum speed (continuous background ventilation), and boost speed, via inbuilt minimum and maximum speed adjustment. The fans shall have infinite variable speed controls.

INTEGRAL AUTOMATIC SUMMER BYPASS

Including Automatic Summer Bypass where intake and return air temperatures shall be measured so that supply air temperatures can be maximised during winter months and minimised as external ambient temperature rises. The Summer Bypass damper shall be opened by a wax actuator. Supply and Extract air shall be filtered irrespective of the bypass setting (open or closed).

INTEGRAL HUMIDITY SENSOR

The integral humidity sensor incorporated within the extract fan chamber will automatically boost both the extract and supply fan, to the commissioned boost speed, when the humidity level exceeds that set by the front panel mounted adjustment potentiometer.

SUMMER/WINTER (SW) SWITCH THIRD SPEED

The unit shall feature volt-free connections for a positional switch controlling the bypass logic profile. Summer setting shall target under 20 degrees C internal dwelling temperature. Winter setting shall ensure heat recovery at all times. Temperature control logic shall be factory pre-set and require no on-site programming. The unit shall feature 3 commissionable speeds for both supply and extract. It shall be possible to enable the unit to its 3rd speed by means of a switch or a programmable thermostat with occupant override CM-THERM-CONTROL. The 3rd speed (overheating) shall be inhibited when outside air temperature exceeds inside temperature and bypass closes so that extracted air cools incoming fresh air.

CONTROL OPTIONS

All versions are built in with the following functions integrally mounted within the fan unit on a purpose made PCB, all such components pre-wired and factory fitted by the manufacturer:

- Independent control of background supply and extract flow rates.
- Independent control of boost speed supply and extract flow rates.
- Run/fault indication to external control systems/BMS via ES-VF.
- Integral S/L terminal for boost from remote switch, e.g. light switch, kitchen boost switch.
- Integral heat exchanger frost protection.
- Discreet daily run monitor.
- Integral humidistat.

The unit comes with 2 years warranty (including parts and labour).

ALL ROUND MVHR SOLUTIONS

MRXBOXAB-ECO5

The MRXBOXAB-ECO5 is a wall mounted MVHR unit with 100% automatic bypass and integral humidistat as listed on the SAP Product Characteristics Database (PCDB).

Owing to its intelligent and smart design, there will be no reduction in airflow when operating in bypass mode, resulting in balanced performance. The unit is designed to provide optimised balanced (supply and extract) mechanical ventilation with heat recovery.

The two airflows pass through the heat exchanger where up to 95% of the heat from the extract air is transferred into the supply air before supplying into the habitable rooms, creating comfortable and well-ventilated homes. The two independent fans have infinitely variable speed control for background and boost ventilation rates.

The ECO5 has a Summer Bypass function which automatically activates in warmer months, to ensure the property is well-ventilated and comfort levels are maintained in the home by continuously drawing in fresh



filtered air into the habitable rooms. The unit is compact enough to go into a cupboard space, as well as being powerful enough to ventilate a kitchen and up to 6 wet rooms.

Units are available as SW versions with a third controllable speed for Approved Document F&O purge rates and additional SW switch to select between seasonal bypass logic profiles.

Opposite Handed (OH) configuration available.



Installation Features:



Performance

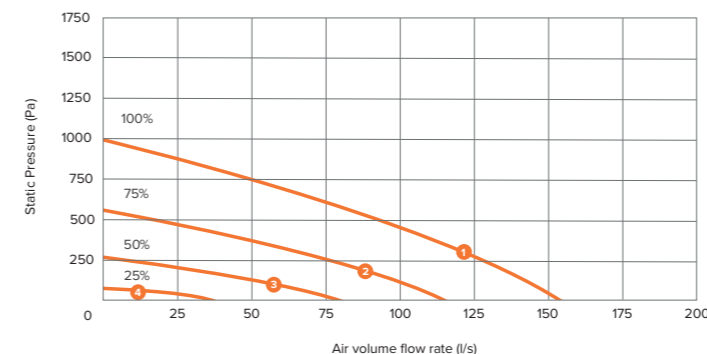

MRXBOXAB-ECO5

Wall mounted unit with 100% bypass and integral humidistat.

MRXBOXAB-ECO5-OH

Opposite Handed configuration wall mounted unit with 100% bypass and integral humidistat.

SUMMER/WINTER SWITCH ONLY (SW)

Units are available as SW versions with a third controllable speed and a Summer/Winter switch, allowing selection of seasonal bypass logic profiles.

Electrical & Sound

ECO5 Sound Data											
Curve	Maximum power consumption (Watts)		Sound Power Levels dB re 1pW (Frequency Hz)							dBA @3m	
			63	125	250	500	1k	2k	4k		8k
1	323	Open inlet	61	61	62	60	53	45	35	32	
		Open outlet	69	69	69	74	67	63	55	49	
		Breakout	70	58	60	60	50	49	42	29	42
2	133	Open inlet	60	61	59	54	51	42	32	23	
		Open outlet	69	68	68	71	64	61	51	42	
		Breakout	70	58	59	57	48	46	36	20	39
3	42	Open inlet	51	50	46	39	36	28	18	<16	
		Open outlet	59	57	54	52	46	43	33	26	
		Breakout	57	50	50	42	35	30	22	<16	26
4	10	Open inlet	40	37	33	25	21	<16	<16	<16	
		Open outlet	47	43	37	32	27	21	<16	<16	
		Breakout	41	38	37	27	18	<16	<16	<16	<16

The maximum power consumption shown above (Watts) is consumed on units running continuously, not taking into account any heat recovery saving and based on SAP Product Characteristics Database (PCDB) testing. The breakout case-radiated dBA values are given for Hemispherical free field radiation at 3m – to obtain the Spherical radiated data, subtract 3 dBA.

Please note: Sound data is provided at a particular duty point for 25%, 50%, 75% and 100%. For accurate sound data at a specific speed duty, please use Nuaire's fan selector or call the office on 029 2085 8500.

SAP/PCDB Data

Product Code	MRXBOXAB-ECO5		
SAP Identifier	MRXBOXAB-ECO5		
Application	Specific Fan Power (W/l/s)	Heat Exchange Efficiency	Energy Saving Trust Best Practice Compliant
Kitchen + 1 Wet Room	0.63	90%	Yes
Kitchen + 2 Wet Rooms	0.61	89%	Yes
Kitchen + 3 Wet Rooms	0.68	88%	Yes
Kitchen + 4 Wet Rooms	0.79	87%	Yes
Kitchen + 5 Wet Rooms	0.91	86%	Yes

Standard Model

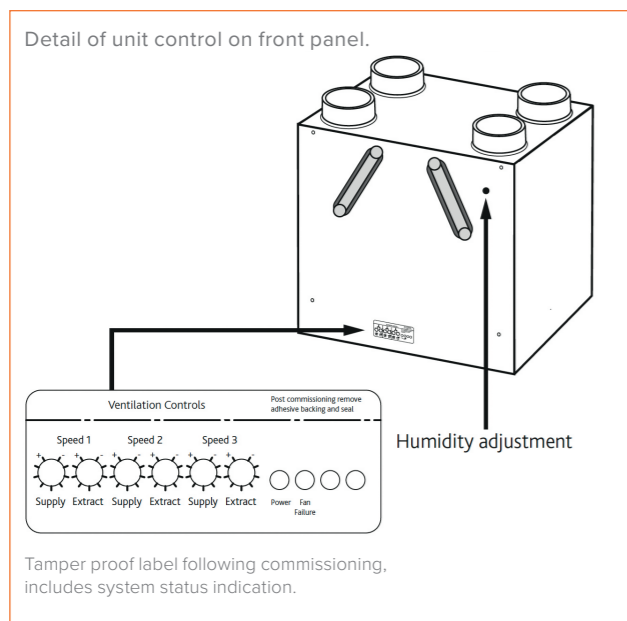

SW Model

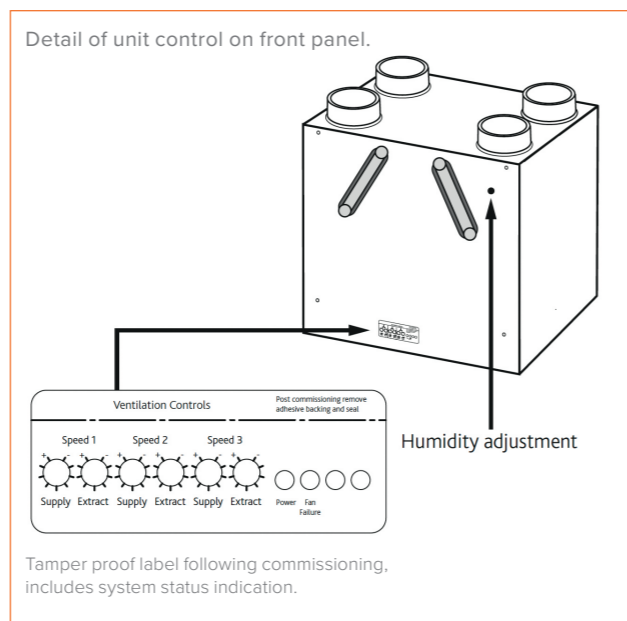

Handing Information

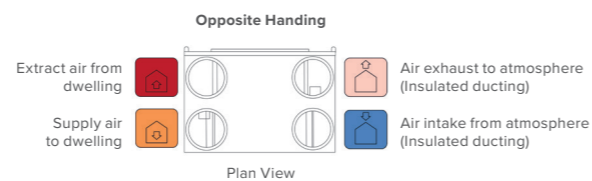
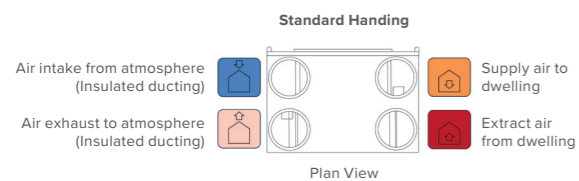

Technical – MRXBOXAB-ECO5

Dimensions (mm) – Standard Unit Configuration

Weight - 25kg

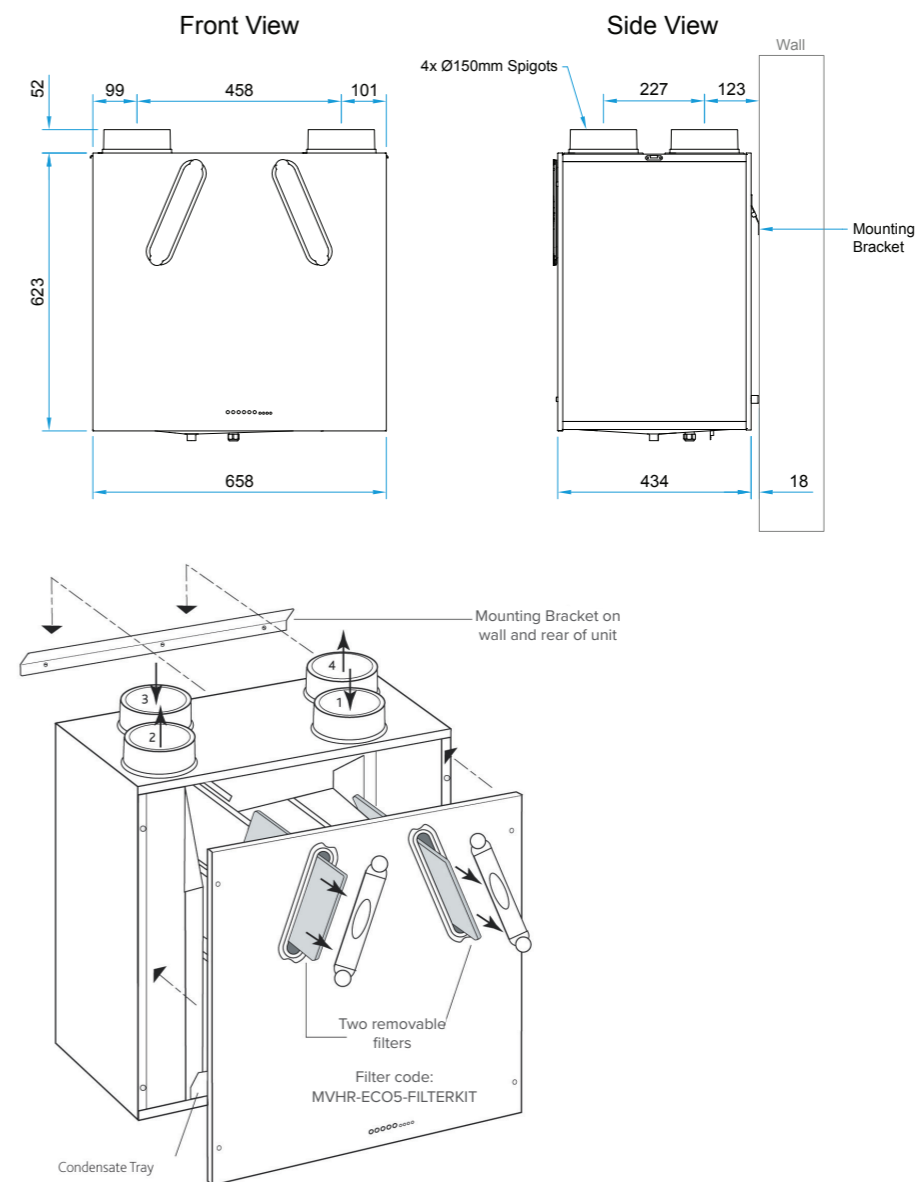

Wiring – MRXBOXAB-ECO5

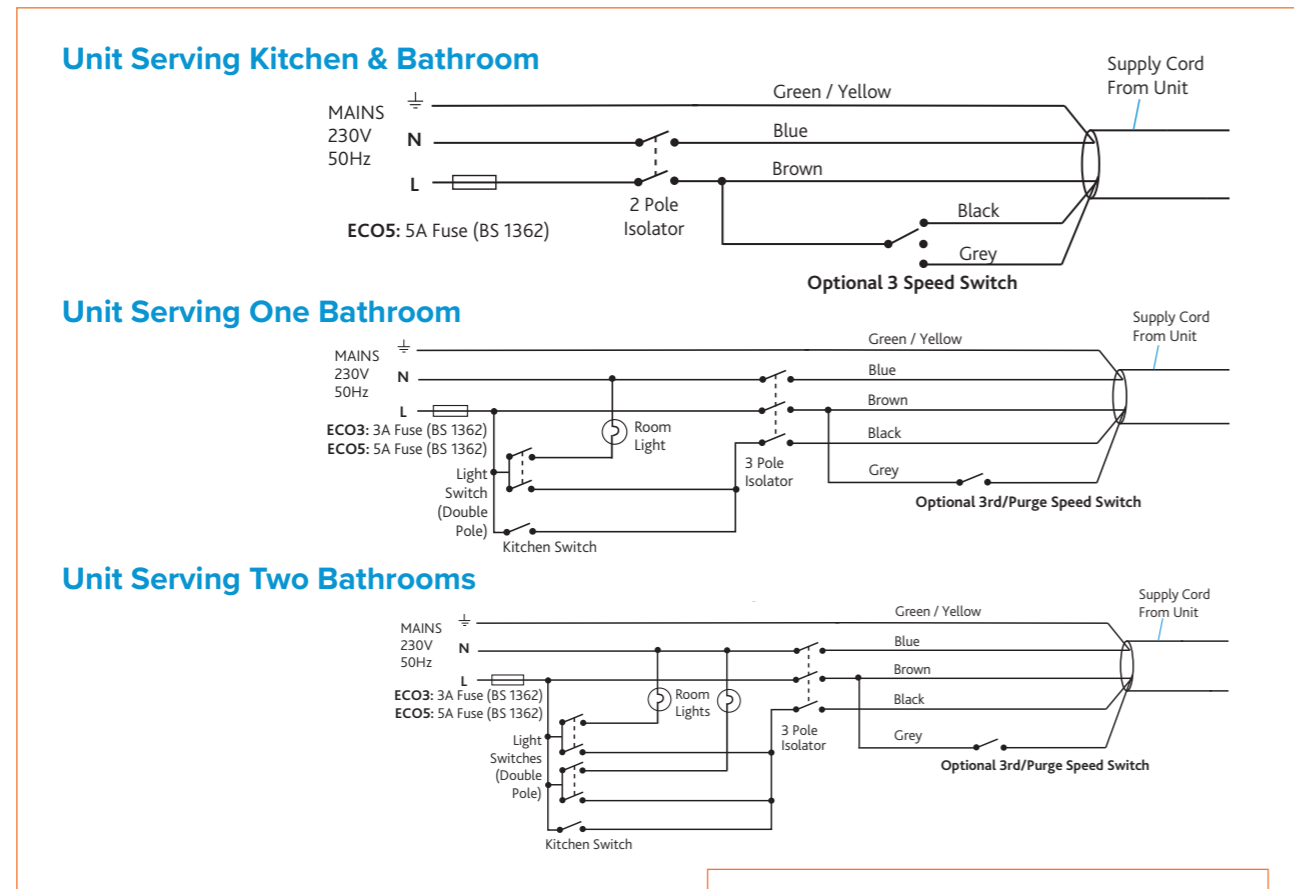

Electrical Details

Please note: the electrical connection of the unit must be carried out by a qualified electrician.

The unit is supplied with a flexible cord for connection to the mains supply. NOTE: This unit must be earthed.

The mains power supply cable should be connected to a fixed wiring installation, via a fused isolator, in accordance with current IEE wiring regulations.

Summer/Winter Switch



Volt free Summer / Winter Switch (supplied with unit)
Polarity is inconsequential
Warning! - Do not connect to mains!

Specification

MRXBOXAB-ECO5

SPECIFICATION

The unit shall be fully insulated providing excellent thermal and acoustic characteristics and shall be complete with a multiplate, counter-flow, high-efficiency heat exchanger block, with a thermal efficiency of up to 95%. The heat exchanger shall be protected by ISO Coarse filters on fresh air inlet and system extract. The heat exchanger and filters shall be accessible via the front access panel, enabling quick and easy maintenance.

The unit shall have low energy, high-efficiency EC fan/motor assemblies with sealed for life bearings, the impellers shall be backward curved centrifugal type. The motors shall be suitable for an ambient temperature of 40°C. The unit shall be supplied complete with an insulated condensate drip tray and 21.5mm drain connection. The unit shall be suitable for 150mm circular ducting. Note: The unit is also available in Opposite Handed format, refer to spigot configuration for set up.

The breakout noise level and power requirements shall be as detailed by the unit manufacturer and in accordance with the ventilation equipment schedule. Units shall be MRXBOXAB-ECO5 as manufactured by Nuaire and shall be listed on the SAP PCDB. MRXBOXAB-ECO5-OH are Opposite Handed assemblies compliant as per standard handed versions listed in SAP PCDB.

OPERATION FOR TWO SPEED (STANDARD MODEL)

The supply and extract system shall be positioned as indicated on the drawings and shall be in accordance with the particular fan schedule in the specification.

The combined supply and extract with heat recovery unit shall supply filtered fresh air to each of the habitable rooms and moisture-laden air shall be extracted from all wet areas, e.g. bathroom, en suite, w.c, kitchen, utility rooms etc. The supply air shall be pre-heated by the warm extract air via the integrated counter-flow heat exchanger element.

The extracted air shall also be filtered before it reaches the heat exchanger block. The ventilation unit shall vary its speed and, therefore, the ventilation rate, as it receives signals from one of the following:

- Switched live signal from light/remote switches/remote switch/humidistat switch.

When signals are received, the fan shall alter its speed to adjustable, normal and boost rates. The unit shall have 3 speeds and the facility to commission the supply and extract fans independently on minimum speed (continuous background ventilation) and boost speed via inbuilt minimum and maximum speed adjustment. The fans shall have infinitely variable speed control.

INTEGRAL AUTOMATIC HX BYPASS WITH NO REDUCTION IN AIRFLOW

The bypass damper shall open automatically via a wax actuator, allowing the air to bypass the heat exchanger to deliver fresh filtered air during the warmer months. The automatic bypass diverts 100% airflow around the heat exchanger with no reduction in airflow, as independently tested by the BRE.

INTEGRAL HUMIDITY SENSOR

The integral humidity sensor incorporated within the extract fan chamber will automatically boost both the extract and supply fan, to the commissioned boost speed, when the humidity level exceeds that set by the front panel mounted adjustment potentiometer.

SUMMER/WINTER (SW) SWITCH THIRD SPEED

The unit shall feature volt-free connections for a positional switch controlling the bypass logic profile. Summer setting shall target under 20 degrees C internal dwelling temperature. Winter setting shall ensure heat recovery at all times. Temperature control logic shall be factory pre-set and require no on-site programming. The unit shall feature 3 commissionable speeds for both supply and extract. It shall be possible to enable the unit to its 3rd speed by means of a switch or a programmable thermostat with occupant override CM-THERM-CONTROL. The 3rd speed (overheating) shall be inhibited when the outside air temperature exceeds the inside air temperature and bypass closes so that extracted air cools incoming fresh air.

CONTROL OPTIONS

All versions are built in with the following functions integrally mounted within the fan unit on a purpose made PCB, all such components pre-wired and factory fitted by the manufacturer:

- Independent control of background supply and extract flow rates.
- Independent control of boost speed supply and extract flow rates.
- Run/fault indication to external control systems/BMS via ES-VF.
- Integral S/L terminal for boost from remote switch, e.g. light switch, kitchen boost switch.
- Integral heat exchanger frost protection.
- Discreet daily run monitor.
- Integral humidistat.

The unit comes with 2 years warranty (including parts and labour).

ACOUSTIC SOLUTIONS

MRXBOXAB-ECO5

Nuaire's First Fix and Acoustic Solution is designed to not only reduce noise but to improve the installation when wall or cupboard mounting the MRXBOXAB-ECO5 unit.

Offering the only complete MVHR acoustic and first fix solution to overcome both noise and ease of installation. The acoustic solution address ducting noise and is an aesthetically pleasing design for cupboard installation.

Opposite Handed (OH) units available.

- Section 1** - First fix plenum chamber
- Section 2** - Silencer box has four airflow chambers, reducing induct noise
- Section 3** - MVHR unit

Installation Features:

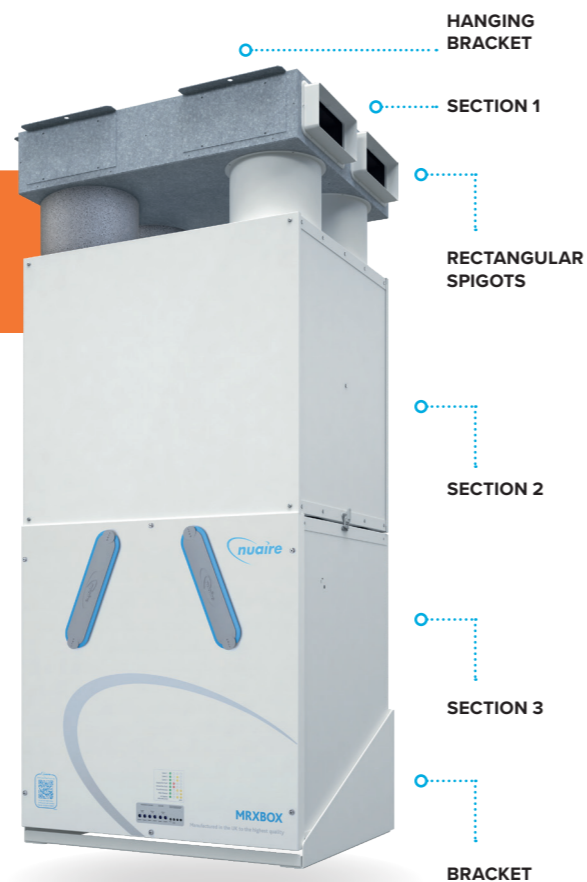
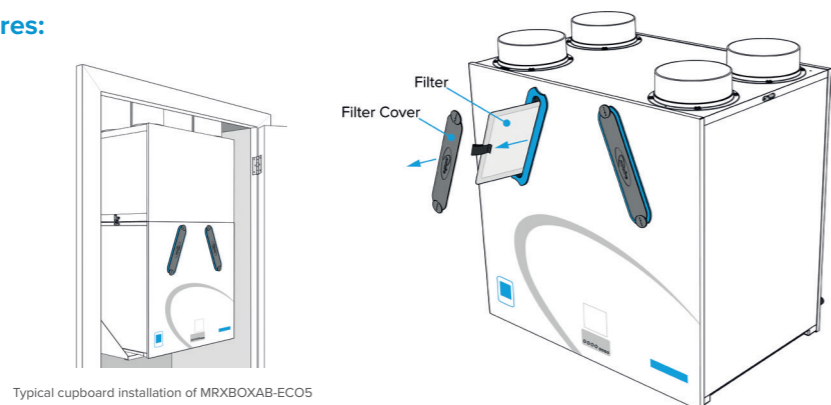

Technical Data

Dimensions (mm) for ECO5 unit

Weight - 25kg

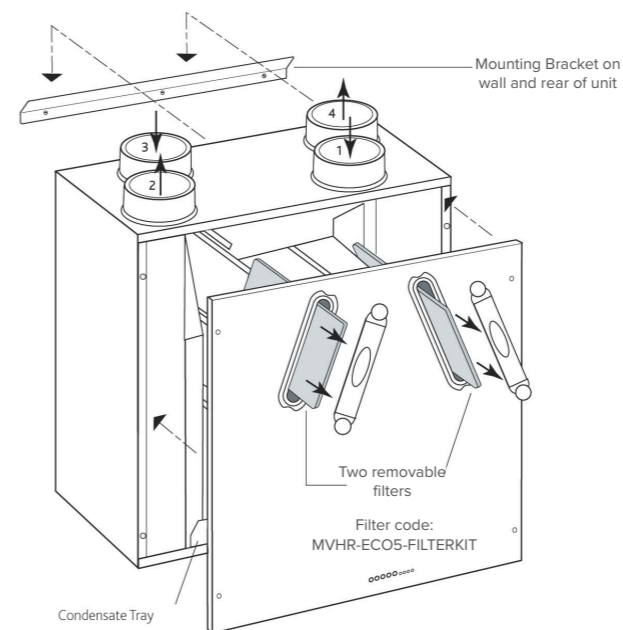
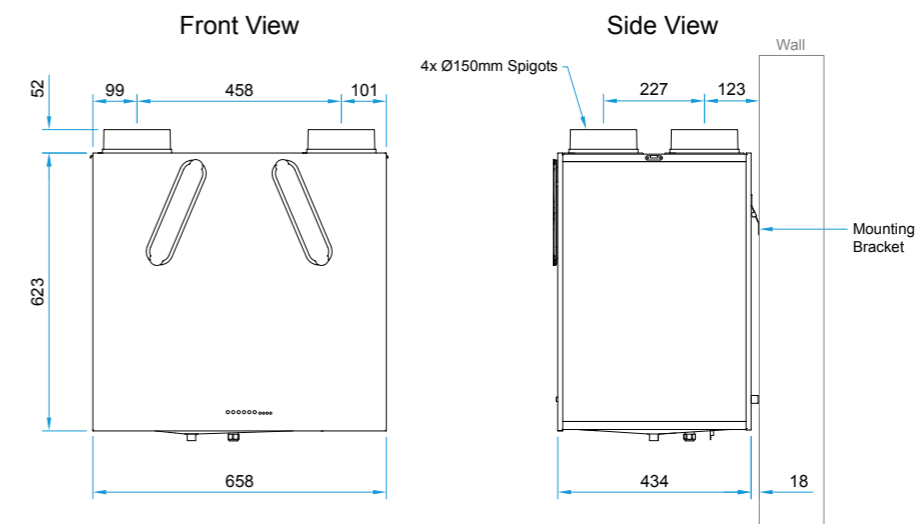

Acoustic data for MRXBOXAB-ECO5 with Silencer and/or First Fix box

Ancillary Sound Data								
MRXBOX-SIL5	63	125	250	500	1K	2K	4K	8K
SUPPLY/DISCHARGE	-11	-7	-8	-12	-20	-26	-19	-14
INTAKE/EXTRACT	-5	-6	-8	-10	-21	-22	-13	-9
MRXBOX-FF5								
SUPPLY/DISCHARGE	-6	-4	-4	-6	-6	-6	-5	-5
INTAKE/EXTRACT	-3	-5	-5	-5	-6	-6	-5	-4
MRXBOX-SIL2+ FF5								
SUPPLY/DISCHARGE	-12	-9	-9	-13	-20	-26	-19	-15
INTAKE/EXTRACT	-7	-9	-10	-11	-21	-22	-14	-10

ACOUSTIC ENCLOSURES

MRXBOXAB-ECO5-AE



The MRXBOXAB-ECO5-AE model is a factory fitted wall mounted MVHR unit. The AE is a wall mounted MVHR unit with a factory fitted acoustic enclosure. Flexible duct connections and anti-vibration mounts are incorporated within the AE providing vibration isolation from the supporting structure and significantly reduces case radiated noise, even at high running speeds.

The unit is equipped to commission the supply and extract fans independently on both minimum and maximum speeds, with the heat exchange blocks being able to recover up to 95% of the wasted heat that has been extracted from the 'wet areas' within the property and at the same time drawing in fresh supply air from outside.

The two independent fans have infinitely variable speed control for background and boost ventilation rates. Nuair guarantee that 100% design airflow rate is maintained in bypass operation.

Units are available as SW versions with a third controllable speed for Approved Document F&O purge rates and additional SW switch to select between seasonal bypass logic profiles.

Opposite Handed (OH) configuration available.



Installation Features:



Performance

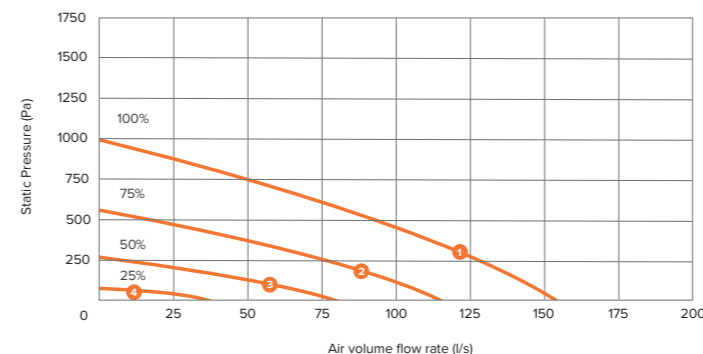

MRXBOXAB-ECO5-AE

Wall mounted unit with 100% bypass and integral humidistat.

MRXBOXAB-ECO5-AE-OH

Opposite Handed configuration wall mounted unit with 100% bypass and integral humidistat.

SUMMER/WINTER SWITCH ONLY (SW)

Units are available as SW versions with a third controllable speed and a Summer/Winter switch, allowing selection of seasonal bypass logic profiles.

Electrical & Sound

EC05-AE Sound Data											
Curve	Maximum power consumption (Watts)		Sound Power Levels dB re 1pW (Frequency Hz)							dBA @3m	
			63	125	250	500	1k	2k	4k		8k
1	323	Open inlet	61	61	62	60	53	45	35	32	
		Open outlet	69	69	69	74	67	63	55	49	
		Breakout	69	57	56	48	33	36	31	20	33
2	133	Open inlet	60	60	69	59	54	51	42	32	
		Open outlet	69	68	68	71	64	61	51	42	
		Breakout	69	57	45	31	33	25	<16	32	23
3	42	Open inlet	50	49	45	38	35	27	17	<16	
		Open outlet	58	56	53	51	45	41	31	24	
		Breakout	55	48	45	29	17	<16	<16	<16	20
4	10	Open inlet	42	36	34	27	23	>16	>16	>16	
		Open outlet	48	45	40	35	30	24	16	<16	
		Breakout	42	39	35	16	>16	>16	>16	>16	10

The maximum power consumption shown above (Watts) is consumed on units running continuously, not taking into account any heat recovery saving and based on SAP Product Characteristics Database (PCDB) testing. The breakout case-radiated dBA values are given for Hemispherical free field radiation at 3m – to obtain the Spherical radiated data, subtract 3 dBA.

Please note: Sound data is provided at a particular duty point for 25%, 50%, 75% and 100%. For accurate sound data at a specific speed duty, please use Nuair's fan selector or call the office on 029 2085 8500.

SAP/PCDB Data

Product Code	MRXBOXAB-ECO5-AE		
SAP Identifier	MRXBOXAB-ECO5		
Application	Specific Fan Power (W/l/s)	Heat Exchange Efficiency	Energy Saving Trust Best Practice Compliant
Kitchen + 1 Wet Room	0.63	90%	Yes
Kitchen + 2 Wet Rooms	0.61	89%	Yes
Kitchen + 3 Wet Rooms	0.68	88%	Yes
Kitchen + 4 Wet Rooms	0.79	87%	Yes
Kitchen + 5 Wet Rooms	0.91	86%	Yes

Standard Model

Detail of unit control on front panel.

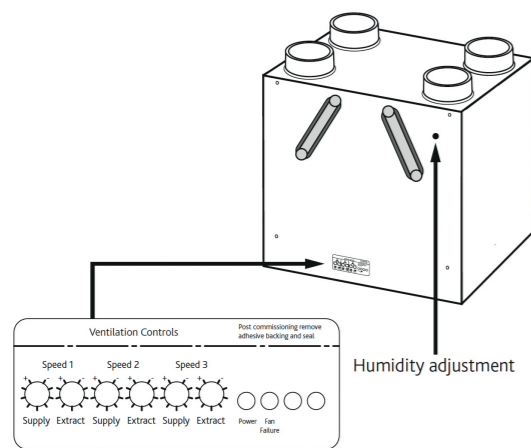

Tamper proof label following commissioning, includes system status indication.

SW Model

Detail of unit control on front panel.

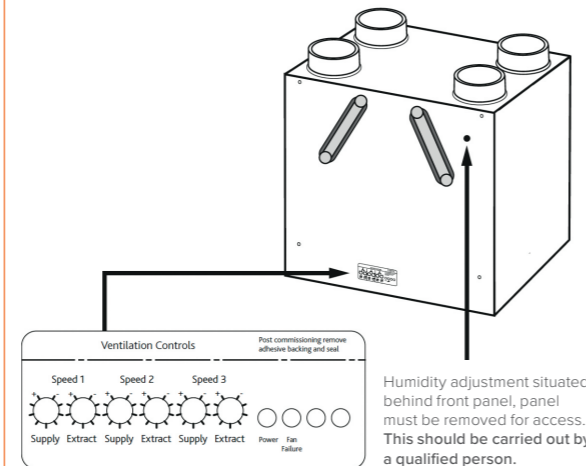

Tamper proof label following commissioning, includes system status indication.

Handing Information

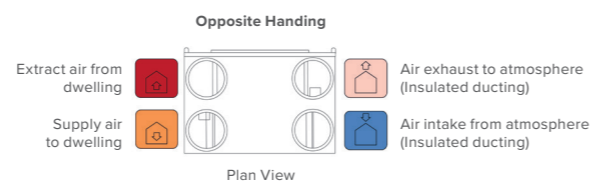
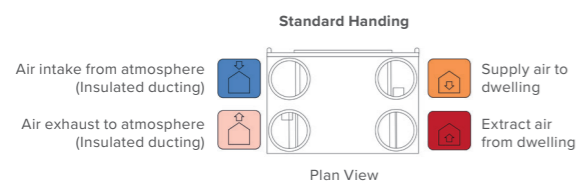

Technical – MRXBOXAB-ECO5-AE

Dimensions (mm) – Standard Unit Configuration

Weight - 56kg

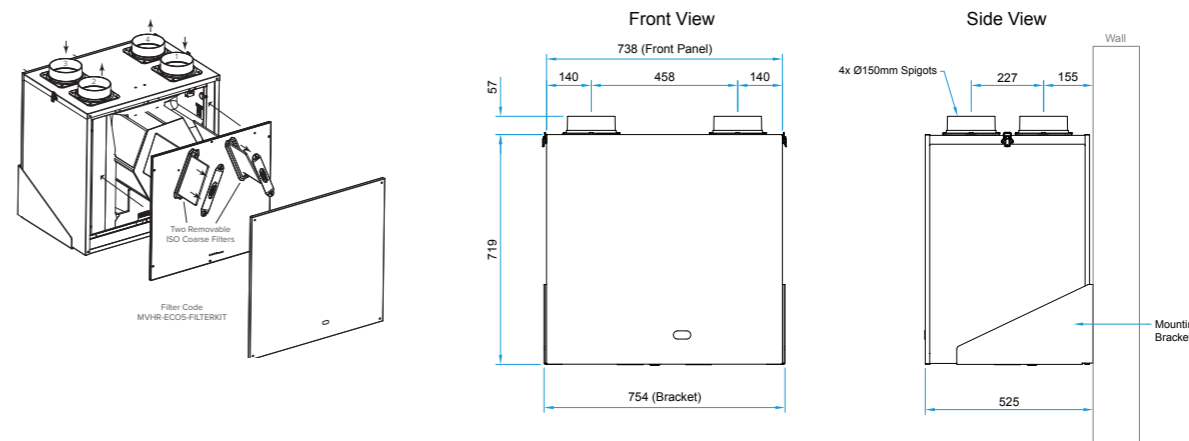

Ancillaries

MRXBOXAB-ECO5-AE

The MRXBOX-DB5 is fitted on top of the MRXBOXAB-ECO5-AE before installation and offers a neat arrangement by directly distributing the initial ducting. It further benefits this MVHR system by reducing any in-line noise breakout, therefore, improving this acoustic solution.

Dimensions (mm)

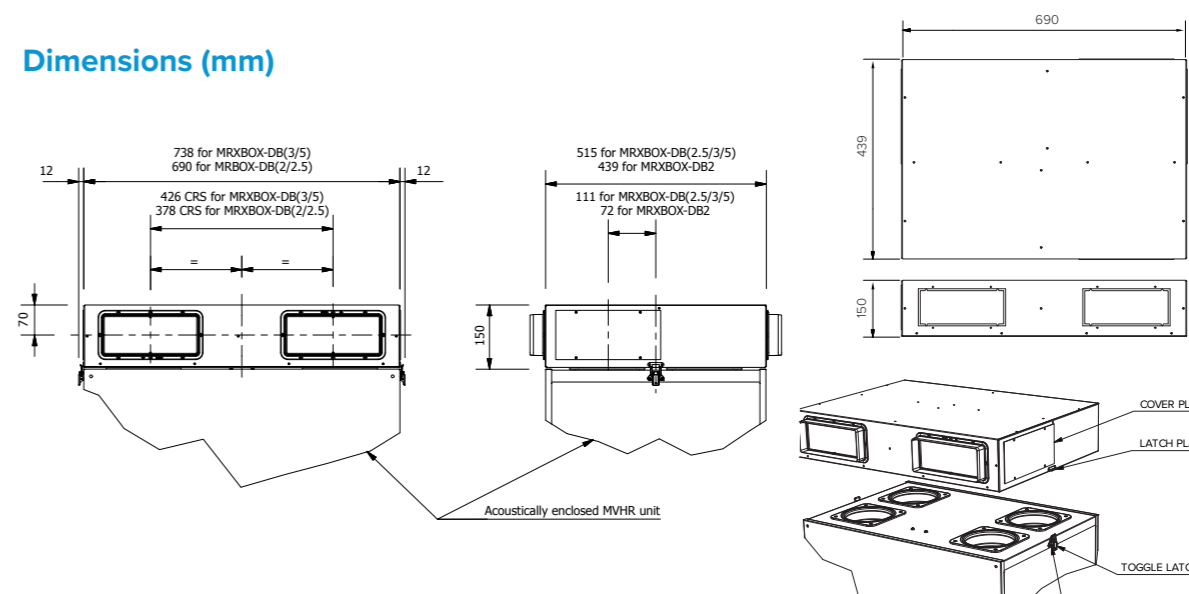

Wiring – MRXBOXAB-ECO5-AE

Unit Serving Kitchen & Bathroom

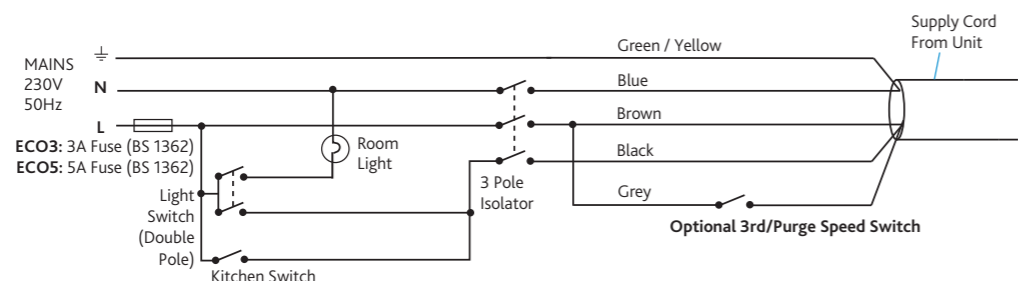

Unit Serving Kitchen & Two Bathrooms

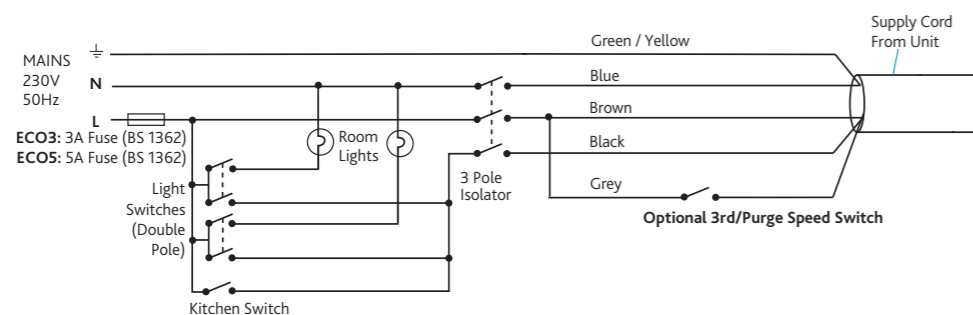

Summer/Winter Switch

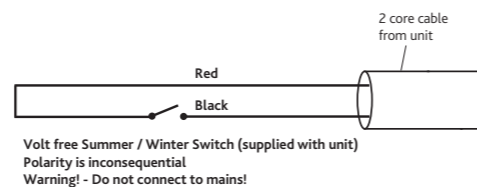

Electrical Details

Please note: the electrical connection of the unit must be carried out by a qualified electrician.

The unit is supplied with a flexible cord for connection to the mains supply. NOTE: This unit must be earthed.

The mains power supply cable should be connected to a fixed wiring installation, via a fused isolator, in accordance with current IEE wiring regulations.

Specification

MRXBOXAB-ECO5-AE

SPECIFICATION

The unit shall be fully insulated providing excellent thermal and acoustic characteristics and shall be complete with a multiplate, counter-flow, high-efficiency heat exchanger block, with a thermal efficiency of up to 95%. The heat exchanger shall be protected by ISO Coarse filters on fresh air inlet and system extract. The heat exchanger and filters shall be accessible via the front access panel, enabling quick and easy maintenance.

The unit shall have low energy, high-efficiency EC fan/motor assemblies with sealed for life bearings, the impellers shall be backward curved centrifugal type. The motors shall be suitable for an ambient temperature of 40°C. The unit shall be supplied complete with an insulated condensate drip tray and 21.5mm drain connection. The unit shall be suitable for 150mm circular ducting. Note: The unit is also available in Opposite Handed format, refer to spigot configuration for set up.

The breakout noise level and power requirements shall be as detailed by the unit manufacturer and in accordance with the ventilation equipment schedule. Units shall be MRXBOXAB-ECO5 as manufactured by Nuaire and shall be listed on the SAP PCDB. MRXBOXAB-ECO5-OH are Opposite Handed assemblies compliant as per standard handed versions listed in SAP PCDB.

OPERATION FOR TWO SPEED (STANDARD MODEL)

The supply and extract system shall be positioned as indicated on the drawings and shall be in accordance with the particular fan schedule in the specification.

The combined supply and extract with heat recovery unit shall supply filtered fresh air to each of the habitable rooms and moisture-laden air shall be extracted from all wet areas, e.g. bathroom, en suite, w.c, kitchen, utility rooms etc. The supply air shall be pre-heated by the warm extract air via the integrated counter-flow heat exchanger element. The extracted air shall also be filtered before it reaches the heat exchanger block.

The ventilation unit shall vary its speed and, therefore, the ventilation rate, as it receives signals from one of the following:

- Switched live signal from light/remote switches/remote switch/ humidistat switch.

When signals are received, the fan shall alter its speed to adjustable, normal and boost rates. The unit shall have 3 speeds and the facility to commission the supply and extract fans independently on minimum speed (continuous background ventilation), and boost speed via inbuilt minimum and maximum speed adjustment. The fans shall have infinite variable speed controls.

INTEGRAL AUTOMATIC HX BYPASS WITH NO REDUCTION IN AIRFLOW

The bypass damper shall open automatically via a wax actuator, allowing the air to bypass the heat exchanger to deliver fresh filtered air during the warmer months. The automatic bypass diverts 100% airflow around the heat exchanger with no reduction in airflow, as independently tested by the BRE.

INTEGRAL HUMIDITY SENSOR

The integral humidity sensor incorporated within the extract fan chamber will automatically boost both the extract and supply fan, to the commissioned boost speed, when the humidity level exceeds that set by the front panel mounted adjustment potentiometer.

SUMMER/WINTER (SW) SWITCH THIRD SPEED

The unit shall feature volt-free connections for a positional switch controlling the bypass logic profile. Summer setting shall target under 20 degrees C internal dwelling temperature. Winter setting shall ensure heat recovery at all times. Temperature control logic shall be factory pre-set and require no on-site programming. The unit shall feature 3 commissionable speeds for both supply and extract. It shall be possible to enable the unit to its 3rd speed by means of a switch or a programmable thermostat with occupant override CM-THERM-CONTROL. The 3rd speed (overheating) shall be inhibited when outside air temperature exceeds inside temperature and bypass closes so that extracted air cools incoming fresh air.

CONTROL OPTIONS

All versions are built in with the following functions integrally mounted within the fan unit on a purpose made PCB, all such components pre-wired and factory fitted by the manufacturer:

- Independent control of background supply and extract flow rates.
- Independent control of boost speed supply and extract flow rates.
- Run/fault indication to external control systems/BMS via ES-VF.
- Integral S/L terminal for boost from remote switch, e.g. light switch, kitchen boost switch.
- Integral heat exchanger frost protection.
- Discreet daily run monitor.
- Integral humidistat.

The unit comes with 2 years warranty (including parts and labour).

ALL IN ONE ACOUSTIC SOLUTION

MRXBOXAB-ECO5-1Z

The MRXBOXAB-ECO5-1Z is the all-in-one acoustic enclosure, allowing the MVHR unit and attenuator to be entirely encased.

With an aesthetically pleasing design enclosing the attenuator, flexible duct connections and anti-vibration mounts that would otherwise be visible, whilst making a significant reduction in case radiated noise.

The unit is equipped to commission the supply and extract fans independently on both minimum and maximum speeds, with the heat exchange blocks being able to recover up to 95% of the wasted heat that has been extracted from the 'wet areas' within the property and at the same time drawing in fresh supply air from outside. The 1Z model is designed to provide optimised balanced (supply and extract) mechanical ventilation heat recovery, whilst offering the best all-in-one acoustic solution on the market.

Units are available as SW versions with a third controllable speed for Approved Document F&O purge rates and additional SW switch to select between seasonal bypass logic profiles.

Opposite Handed (OH) configuration available.



Installation Features:



Performance

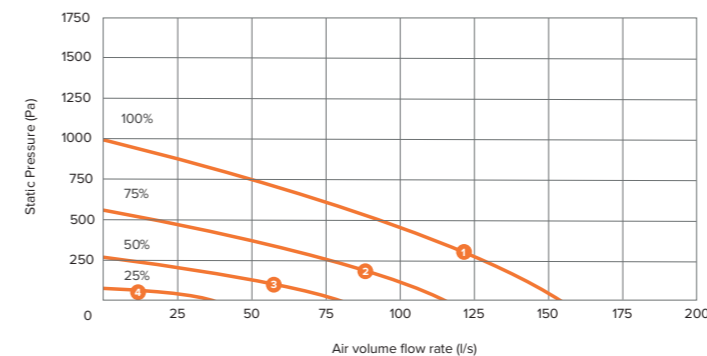

MRXBOXAB-ECO5-1Z

Wall mounted unit with 100% bypass and integral humidistat.

MRXBOXAB-ECO5-1Z-OH

Opposite Handed configuration wall mounted unit with 100% bypass and integral humidistat.

SUMMER/WINTER SWITCH ONLY (SW)

Units are available as SW versions with a third controllable speed and a Summer/Winter switch, allowing selection of seasonal bypass logic profiles.

Electrical & Sound

ECO5-1Z Sound Data											
Curve	Maximum power consumption (Watts)		Sound Power Levels dB re 1pW (Frequency Hz)							dBA @3m	
			63	125	250	500	1K	2K	4K		8K
1	323	Open inlet	56	55	54	50	32	23	22	23	
		Open outlet	63	62	61	62	47	37	36	35	
		Breakout	70	58	56	47	30	28	27	20	33
2	133	Open inlet	55	55	51	44	30	20	19	<16	
		Open outlet	63	61	60	59	44	35	32	28	
		Breakout	70	58	55	44	29	25	21	<16	32
3	42	Open inlet	46	44	38	29	<16	<16	<16	<16	
		Open outlet	53	50	46	40	26	17	<16	<16	
		Breakout	57	50	45	29	<16	<16	<16	<16	21
4	10	Open inlet	38	35	30	22	<16	<16	<16	<16	
		Open outlet	44	40	34	27	19	<16	<16	<16	
		Breakout	41	38	35	22	<16	<16	<16	<16	<16

The maximum power consumption shown above (Watts) is consumed on units running continuously, not taking into account any heat recovery saving and based on SAP Product Characteristics Database (PCDB) testing. The breakout case-radiated dBA values are given for Hemispherical free field radiation at 3m – to obtain the Spherical radiated data, subtract 3 dBA.

Please note: Sound data is provided at a particular duty point for 25%, 50%, 75% and 100%. For accurate sound data at a specific speed duty, please use Nuaire's fan selector or call the office on 029 2085 8500.

SAP/PCDB Data

Product Code	MRXBOXAB-ECO5-1Z		
SAP Identifier	MRXBOXAB-ECO5		
Application	Specific Fan Power (W/l/s)	Heat Exchange Efficiency	Energy Saving Trust Best Practice Compliant
Kitchen + 1 Wet Room	0.63	90%	Yes
Kitchen + 2 Wet Rooms	0.61	89%	Yes
Kitchen + 3 Wet Rooms	0.68	88%	Yes
Kitchen + 4 Wet Rooms	0.79	87%	Yes
Kitchen + 5 Wet Rooms	0.91	86%	Yes

Standard Model

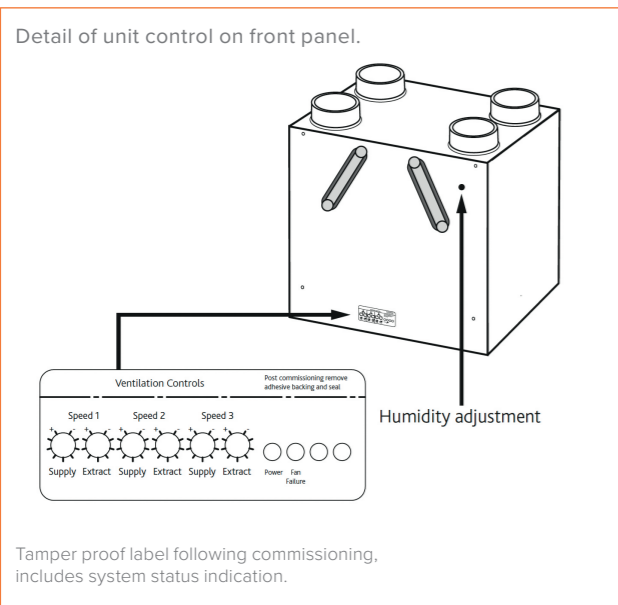

SW Model

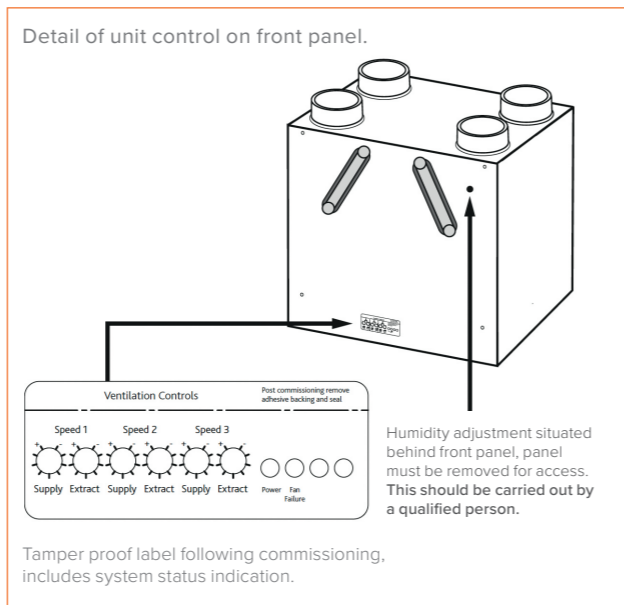

Handing Information

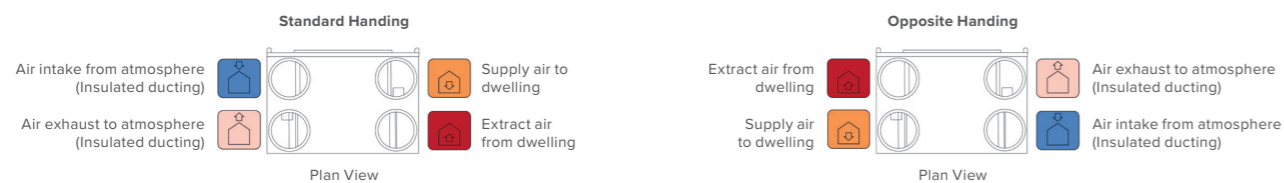

Technical – MRXBOXAB-ECO5-1Z

Dimensions (mm) – Standard Unit Configuration

Weight - 76kg

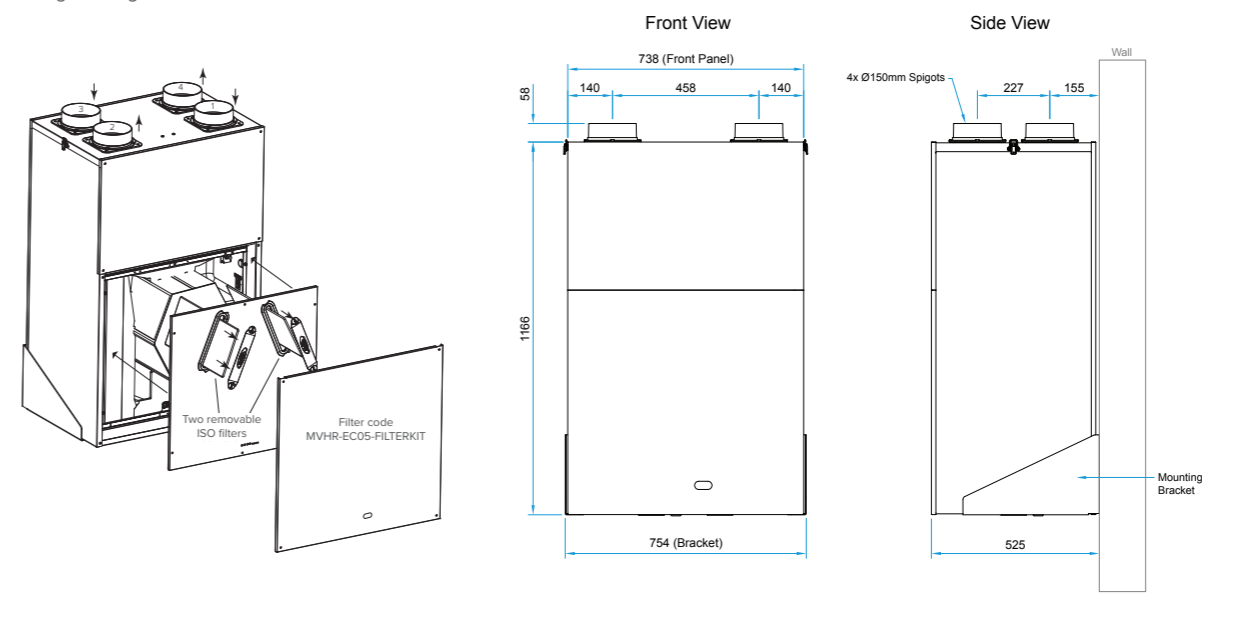

Ancillaries

MRXBOX-DB5

The MRXBOX-DB5 is fitted on top of the MRXBOXAB-ECO5-1Z before installation and offers a neat arrangement by directly distributing the initial ducting. It further benefits this MVHR system by reducing any in-line noise breakout, therefore, improving this acoustic solution.

Dimensions (mm)

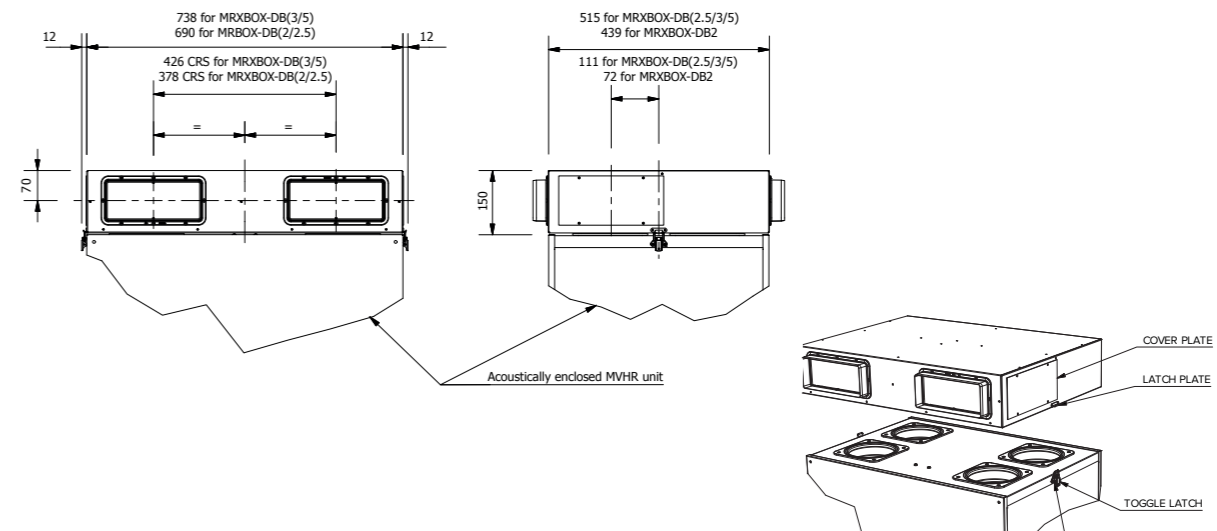

Wiring – MRXBOXAB-ECO5-1Z

Unit Serving Kitchen

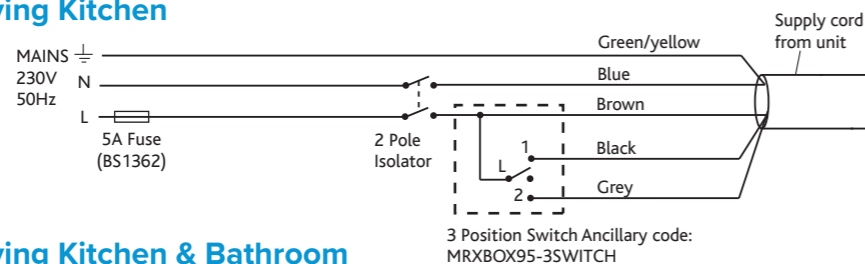

Unit Serving Kitchen & Bathroom

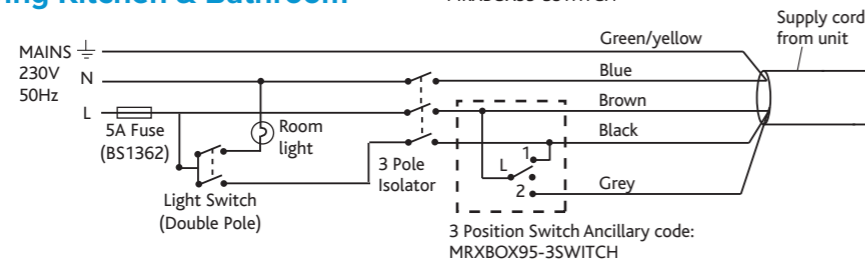

Unit Serving Kitchen & Two Bathrooms

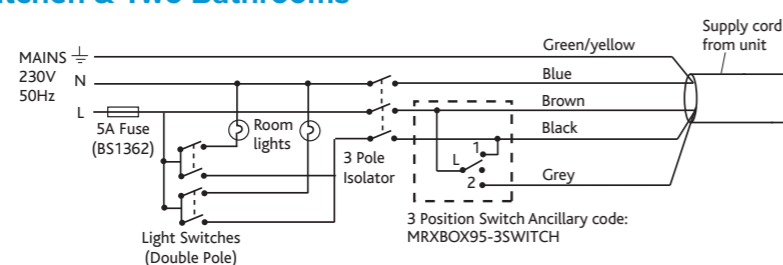

Electrical Details

Please note: the electrical connection of the unit must be carried out by a qualified electrician.

The unit is supplied with a flexible cord for connection to the mains supply. NOTE: This unit must be earthed.

The mains power supply cable should be connected to a fixed wiring installation, via a fused isolator, in accordance with current IEE wiring regulations.

Summer/Winter Switch

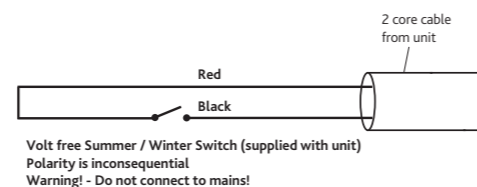

Specification

MRXBOXAB-ECO5-1Z

SPECIFICATION

The unit shall be fully insulated providing excellent thermal and acoustic characteristics and shall be complete with a multi plate counter flow high efficiency heat exchanger block, with a thermal efficiency of up to 95%. The heat exchanger shall be protected by ISO Coarse filters on fresh air inlet and system extract. The heat exchanger and filters shall be accessible via the front access panel, enabling quick and easy maintenance.

The unit shall have low energy, high efficiency EC fan/motor assemblies with sealed for life bearings, the impellers shall be backward curved centrifugal type. The motors shall be suitable of an ambient temperature of 40°C. The unit shall be supplied complete with a condensate drip tray and 21.5mm drain connection. The unit shall be suitable for 150mm diameter circular ducting. The breakout noise level and power requirements shall be as detailed by the unit manufacturer and in accordance with the ventilation equipment schedule. Units shall be one of MRXBOXAB-ECO5-1Z and MRXBOXAB-ECO5-1Z-OH as manufactured by Nuaire. The unit shall be provided within a white pre-painted or coated steel acoustic enclosure lined with a minimum of 20mm class '0' acoustic foam insulation to reduce breakout noise.

In-duct noise shall be attenuated on Intake/Exhaust/Supply/Extract by means of a 4-way attenuator mounted within the enclosure and close coupled directly to the unit. Flexible duct connections shall be within the enclosure, pre-fitted between the attenuator section and the connection spigots on the top face of the enclosure. (Removing the need for flexible duct connectors outside of the unit which may cause breakout). The MVHR unit and attenuator assembly shall be retained within the enclosure on a metal tray supported on turret type anti-vibration mounts of suitable deflection to ensure that vibration is not transmitted to the supporting structure.

OPERATION FOR TWO SPEED (STANDARD MODEL)

The supply and extract ventilation unit shall be positioned as indicated on the drawings and shall be in accordance with the particular fan schedule in the specification.

This unit is also available in Opposite Handed formatting. The combined supply and extract with heat recovery unit, shall supply filtered fresh air to each of the habitable rooms and vitiated air shall be extracted from the wet areas e.g. bathroom, en-suite, w.c, kitchen, utility rooms, etc. The supply air shall be pre-heated by the warm extract air via the integrated counter-flow heat exchanger element. The extracted air shall also be filtered before it reaches the heat exchanger block.

The ventilation unit shall vary its speed and, therefore, the ventilation rate, as it receives signals from one of the following:

- Switched live signal from light/remote switches/remote switch/humidistat switch.

When signals are received, the fan shall alter its speed to adjustable, normal and boost rates. The unit shall have the facility to commission the supply and extract fans independently on minimum speed (continuous background ventilation), and boost speed, via inbuilt minimum and maximum speed adjustment. The fans shall have infinitely variable speed control.

INTEGRAL AUTOMATIC HX BYPASS WITH NO REDUCTION IN AIRFLOW

Including Automatic Summer Bypass where intake and return air temperatures shall be measured so that supply air temperatures can be maximised during winter months and minimised as external ambient temperature rises. The Summer Bypass damper shall be opened by a wax actuator. Supply and Extract air shall be filtered irrespective of the bypass setting (open or closed).

INTEGRAL HUMIDITY SENSOR

The integral humidity sensor incorporated within the extract fan chamber will automatically boost both the extract and supply fan, to the commissioned boost speed, when the humidity level exceeds that set by the front panel mounted adjustment potentiometer.

SUMMER/WINTER (SW) SWITCH THIRD SPEED

The unit shall feature volt-free connections for a positional switch controlling the bypass logic profile. Summer setting shall target under 20 degrees C internal dwelling temperature. Winter setting shall ensure heat recovery at all times. Temperature control logic shall be factory pre-set and require no on-site programming. The unit shall feature 3 commissionable speeds for both supply and extract. It shall be possible to enable the unit to its 3rd speed by means of a switch or a programmable thermostat with occupant override CM-THERM-CONTROL. The 3rd speed (overheating) shall be inhibited when outside air temperature exceeds inside temperature and bypass closes so that extracted air cools incoming fresh air.

CONTROL OPTIONS

All versions are built in with the following functions integrally mounted within the fan unit on a purpose made PCB, all such components pre-wired and factory fitted by the manufacturer:

- Independent control of background supply and extract flow rates.
- Independent control of boost speed supply and extract flow rates.
- Run/fault indication to external control systems/BMS via ES-VF.
- Integral S/L terminal for boost from remote switch, e.g. light switch, kitchen boost switch.
- Integral heat exchanger frost protection.
- Discreet daily run monitor.
- Integral humidistat.

The unit comes with 2 years warranty (including parts and labour).

MVHR SOLUTION

MRXBOX95AB-WM1

The MRXBOX95AB-WM1 is a wall mounted MVHR unit.

The heat exchanger block within these units can recover up to 95% of the normally wasted heat. The two independent fans have full-speed control for background and boost ventilation rates.

The unit has a Summer Bypass function. In warmer months this function automatically activates to ensure the property is being well-ventilated and comfort levels are maintained in the home by continuously drawing in fresh filtered air into the habitable rooms.

Opposite Handed (OH) configuration available.



Performance

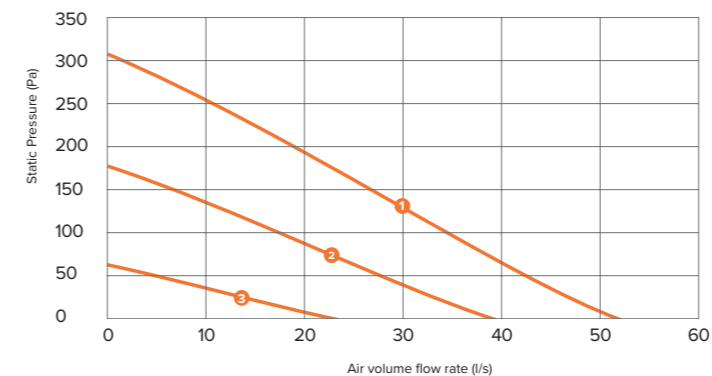

MRXBOX95AB-WM1

Wall mounted unit with 100% bypass and integral humidistat.

MRXBOX95AB-WM1-OH

Opposite Handed configuration wall mounted unit with 100% bypass and integral humidistat.

Electrical & Sound

WM1 Sound Data											
Curve	Maximum power consumption (Watts)		Sound Power Levels dB re 1pW (Frequency Hz)								dBA @3m
			63	125	250	500	1K	2K	4K	8K	
1	69	Open inlet	45	41	48	47	41	39	24	24	
		Open outlet	48	51	57	59	54	47	39	33	41
		Breakout	51	50	53	51	43	38	30	26	33
2	32	Open inlet	43	39	45	43	35	33	18	18	
		Open outlet	46	49	54	55	48	41	33	27	
		Breakout	49	48	47	47	37	32	24	20	29
3	7	Open inlet	40	35	39	35	23	21	<16	<16	
		Open outlet	43	45	48	47	36	29	21	<16	
		Breakout	46	44	44	39	25	20	<16	<16	21

The maximum power consumption shown above (Watts) is consumed on units running continuously, not taking into account any heat recovery saving and based on SAP Product Characteristics Database (PCDB) testing. The breakout case-radiated dBA values are given for Hemispherical free field radiation at 3m – to obtain the Spherical radiated data, subtract 3 dBA.

Please note: Sound data is provided at a particular duty point for 25%, 50%, 75% and 100%. For accurate sound data at a specific speed duty, please use Nuaire's fan selector or call the office on 029 2085 8500.

Installation Features:



SAP/PCDB Data

Product Code	MRXBOX95AB-WM1		
SAP Identifier	MRXBOX95AB-WM1		
Application	Specific Fan Power (W/l/s)	Heat Exchange Efficiency	Energy Saving Trust Best Practice Compliant
Kitchen + 1 Wet Room	0.91	86%	Yes

General Arrangement

STANDARD UNIT Spigot Location & Ducting References

Spigot 1. 125mm dia. = Extract air from dwelling.
 Spigot 2. 125mm dia. = Exhaust air to outside.
 Spigot 3. 125mm dia. = Intake air from outside.
 Spigot 4. 125mm dia. = Supply air to property.

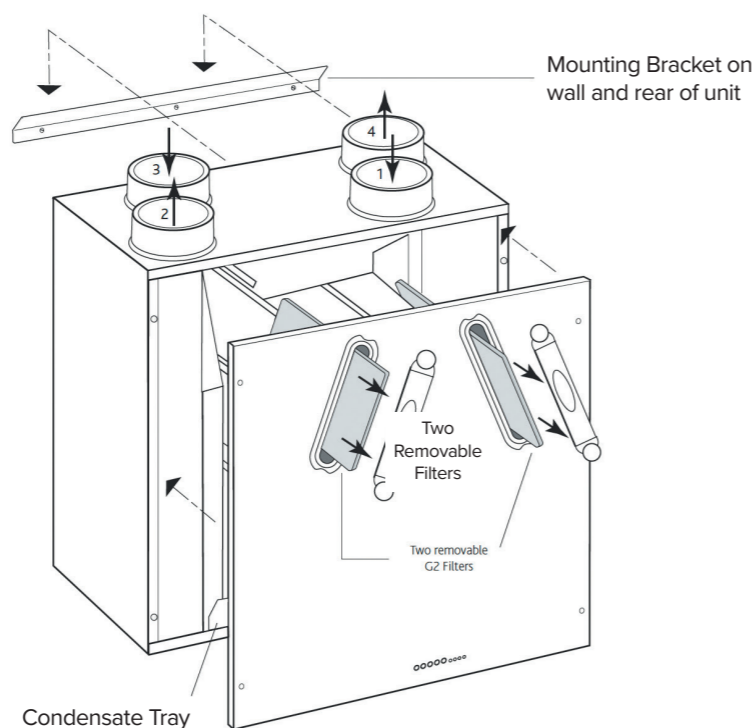
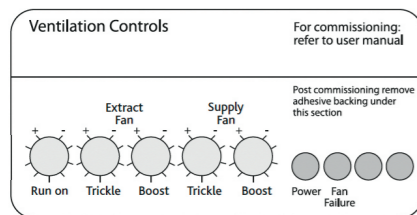

Handing Information

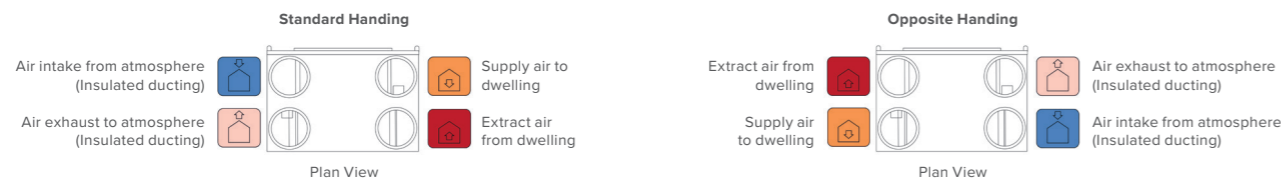

Technical – MRXBOX95AB-WM1

Dimensions (mm) – Standard Unit Configuration

Weight - 16kg

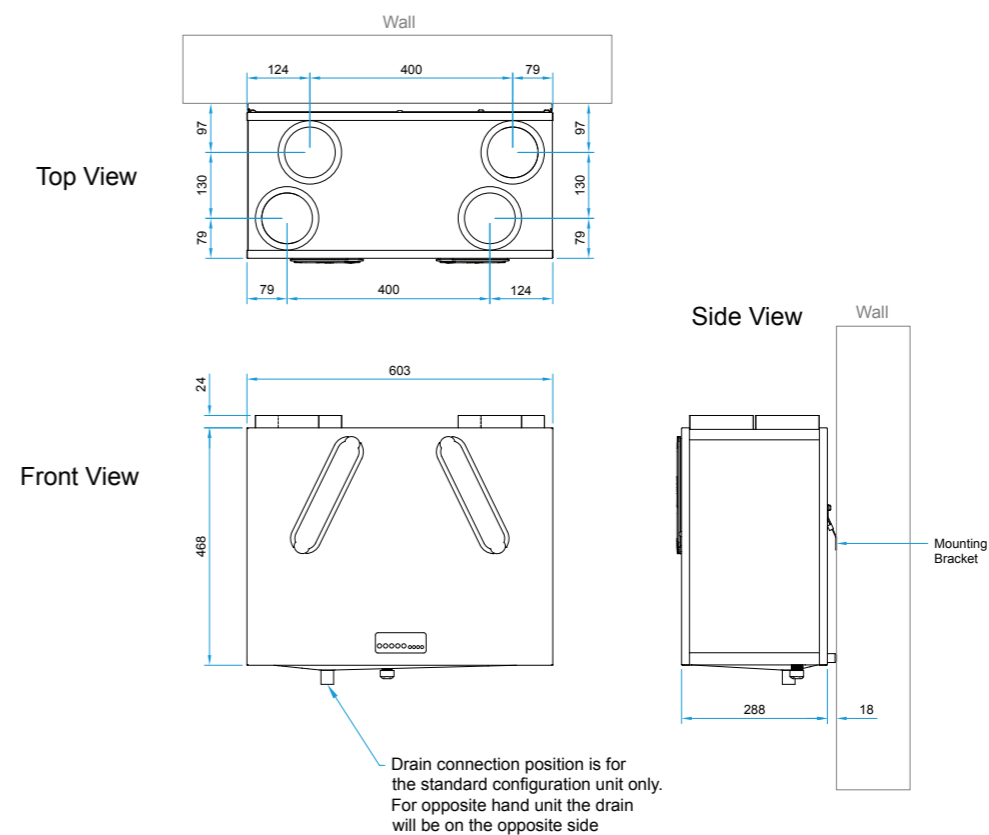

Standard Model

Detail of unit control on front panel.

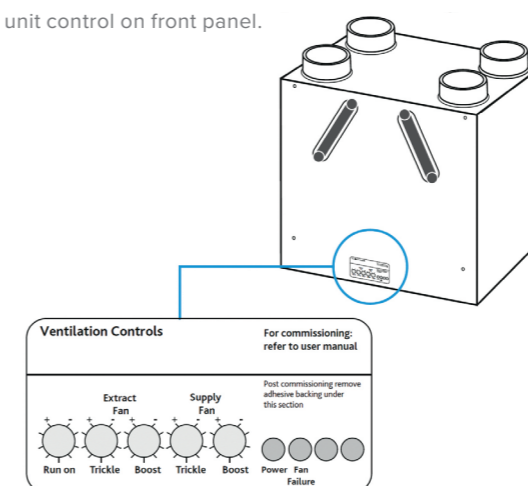

Tamper proof label following commissioning, includes system status indication.

Wiring – MRXBOX95AB-WM1

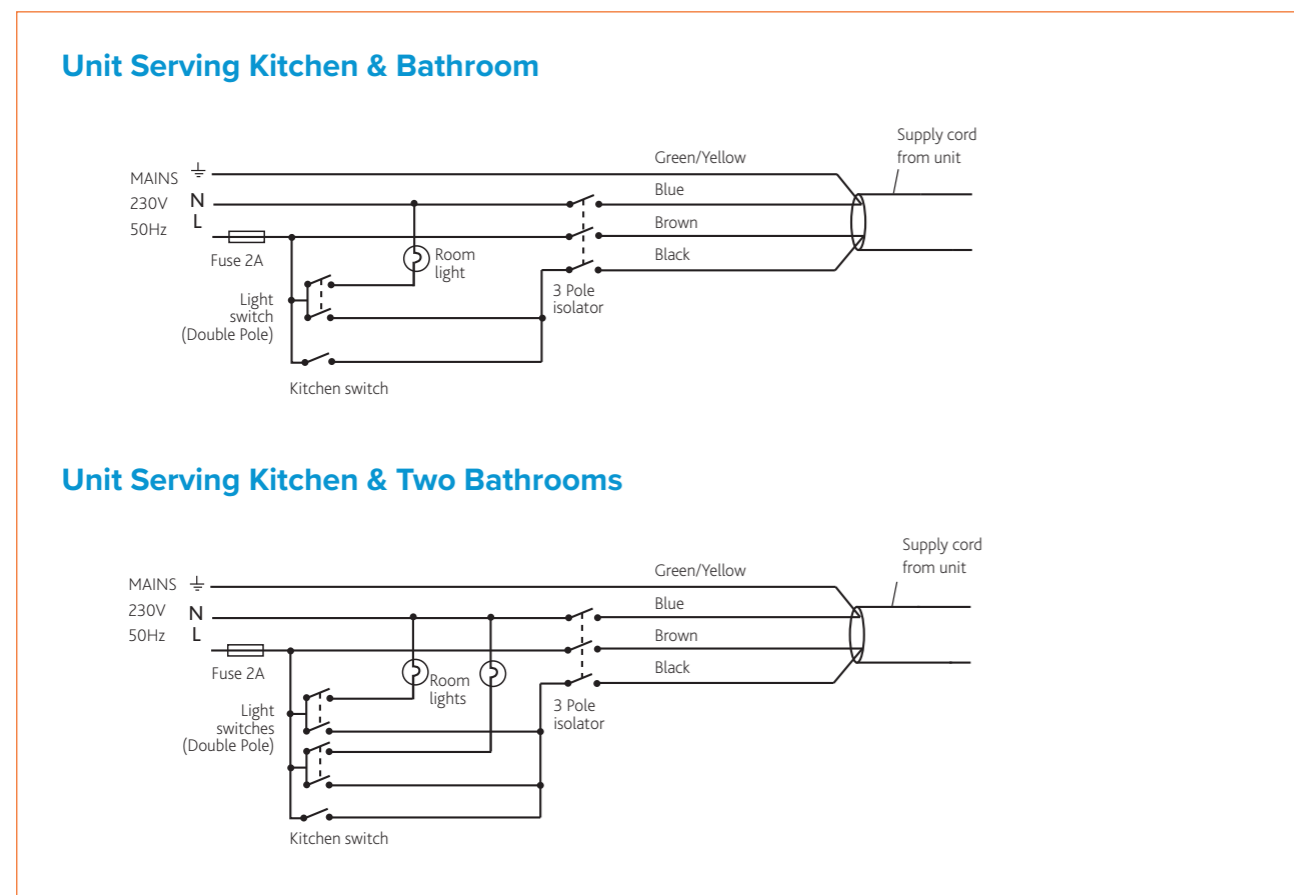

Electrical Details

Please note: the electrical connection of the unit must be carried out by a qualified electrician.

The unit is supplied with a flexible cord for connection to the mains supply. NOTE: This unit must be earthed.

The mains power supply cable should be connected to a fixed wiring installation, via a fused isolator, in accordance with current IEE wiring regulations.

Specification

MRXBOX95AB-WM1

SPECIFICATION

The unit shall be fully insulated providing excellent thermal and acoustic characteristics and shall be complete with a multi plate counter flow high efficiency heat exchanger block, with a thermal efficiency of up to 95%. The heat exchanger shall be protected by ISO coarse grade filters on fresh air inlet and system extract. The heat exchanger and filters shall be accessible via the front access panel, enabling quick and easy maintenance. The unit shall have low energy, high efficiency d.c fan/motor assemblies with sealed for life bearings, the impellers shall be backward curved centrifugal type. The motors shall be suitable of an ambient temperature of 40°C.

The unit shall be supplied complete with an insulated condensate drip tray and 21.5mm drain connection. The unit shall be suitable for 125mm circular ducting.

Note: The unit is also available in Opposite Handed format, refer to spigot configuration for set up.

The breakout noise level and power requirements shall be as detailed by the unit manufacturer and in accordance with the ventilation equipment schedule.

Units shall be MRXBOX95AB-WM1 as manufactured by Nuaire and shall be listed on the SAP Product Characteristics Database (PCDB).

OPERATION FOR TWO SPEED

The supply and extract system shall be wall/cupboard mounted in accordance with the specification.

The combined supply and extract with heat recovery unit shall supply filtered fresh air to each of the habitable rooms and moisture-laden air shall be extracted from all wet areas, e.g. bathroom, en suite, w.c, kitchen, utility rooms etc. The supply air shall be pre-heated by the warm extract air via the integrated counter-flow heat exchanger element.

The ventilation unit shall vary its speed and, therefore, the ventilation rate, as it receives signals from one of the following:

- Switched live signal from light/remote switches/remote switch/ humidistat switch.
- Optional externally interconnected sensors.

When signals are received, the fan shall alter its speed to adjustable, normal and boost rates.

An adjustable run-on facility is integrated into the unit which allows the fans to run-on for between 1 and 60 minutes after the signals have been switched off.

The unit shall have the facility to commission the supply and extract fans independently on minimum speed (continuous background ventilation), and boost speed, via inbuilt minimum and maximum speed adjustment. The fans shall have infinitely variable speed control.

INTEGRAL AUTOMATIC HX BYPASS

The bypass damper shall open automatically via a wax actuator, allowing the air to bypass the heat exchanger to deliver fresh filtered air during the warmer months.

CONTROL OPTIONS

All versions shall have the following functions integrally mounted within the fan unit on a purpose made PCB, all such components pre-wired and factory fitted by the manufacturer:

- Independent control of background supply and extract flow rates.
- Independent control of boost speed supply and extract flow rates.
- Integral heat exchanger frost protection.
- Integral adjustable run on timer.
- Run/fault indication to external control systems/BMS via ES-VF.
- Integral S/L terminal for boost from remote switch, e.g. light switch.
- Indication and controls – The unit shall have clear LED visual indication for maintenance, servicing and operation mode, i.e. summer bypass, frost protection.

The unit comes with 2 years warranty (including parts and labour).

Low Profile Unit

MRXBOXAB-ECO-LP2

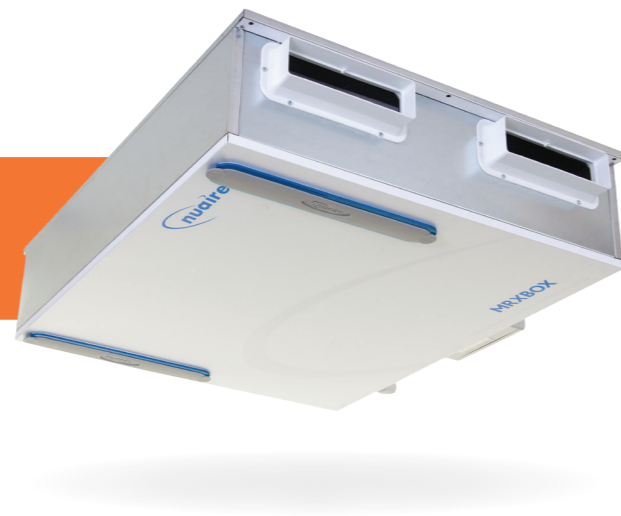

The MRXBOXAB-ECO-LP2 low profile MVHR unit with 100% automatic bypass as listed on the SAP Product Characteristics Database (PCDB).

This model is mounted within the ceiling void space and is specifically designed to fit easily into apartments with ceiling void restrictions, where space is at a premium.

The LP2 has a Summer Bypass function which automatically activates in warmer months to ensure the property is well-ventilated and comfort levels are maintained in the home by continuously drawing in fresh filtered air into the habitable rooms.

It is also designed to be compatible with the latest generation of controls and sensors. Suitable for small to medium-sized properties with a kitchen plus 4 wet rooms.

Units are available as SW versions with a third controllable speed for Approved Document F&O purge rates and additional SW switch to select between seasonal bypass logic profiles.

Opposite Handed (OH) configuration available.

Installation Features:

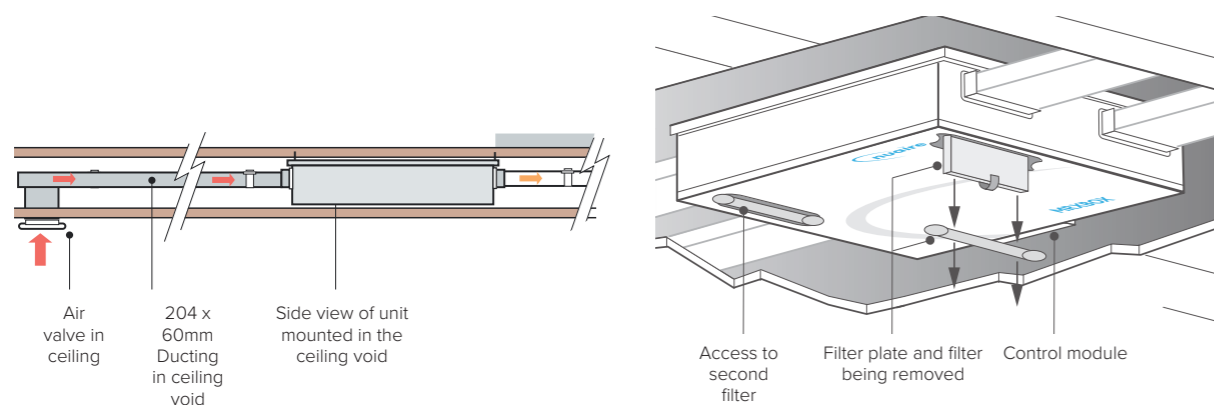

Performance

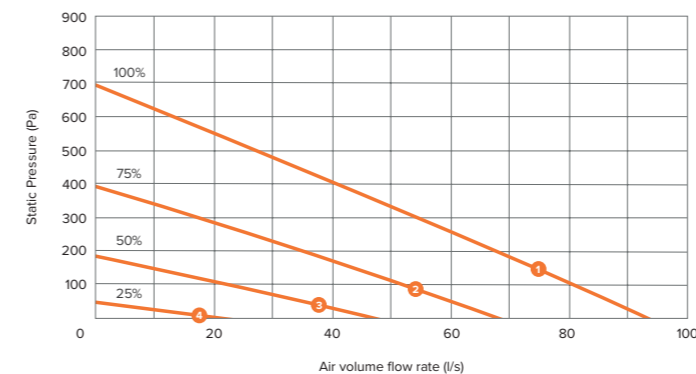

MRXBOXAB-ECO-LP2

Low profile multi-room supply and extract heat recovery with automatic Summer Bypass.

MRXBOXAB-ECO-LP2-OH

Low profile multi-room supply and extract heat recovery with automatic Summer bypass with reverse handing.

SUMMER/WINTER SWITCH ONLY (SW)

Units are available as SW versions with a third controllable speed and a Summer/Winter switch allowing selection of seasonal bypass logic profiles.

Electrical & Sound

LP2 Sound Data											
Curve	Maximum power consumption (Watts)		Sound Power Levels dB re 1pW (Frequency Hz)								dBA @3m
			63	125	250	500	1k	2k	4k	8k	
1	163	Open inlet	51	45	50	48	40	42	29	19	
		Open outlet	54	49	59	64	61	60	51	43	
		Breakout	58	60	61	58	48	41	33	25	40
2	69	Open inlet	51	43	46	44	36	36	22	<16	
		Open outlet	51	45	54	59	55	54	44	34	
		Breakout	54	57	56	52	41	34	25	18	34
3	22	Open inlet	45	37	34	32	24	23	<16	<16	
		Open outlet	44	37	43	46	43	41	29	19	
		Breakout	47	50	44	40	30	22	<16	<16	23
4	7	Open inlet	38	31	24	22	<16	<16	<16	<16	
		Open outlet	37	30	33	36	33	31	19	<16	
		Breakout	40	43	34	30	20	<16	<16	<16	<16

The maximum power consumption shown above (Watts) is consumed on units running continuously, not taking into account any heat recovery saving and based on SAP Product Characteristics Database (PCDB) testing. The breakout case-radiated dBA values are given for Hemispherical free field radiation at 3m – to obtain the Spherical radiated data, subtract 3 dBA.

Please note: Sound data is provided at a particular duty point for 25%, 50%, 75% and 100%. For accurate sound data at a specific speed duty, please use Nuair's fan selector or call the office on 029 2085 8500.

SAP/PCDB Data

Product Code	MRXBOXAB-ECO-LP2		
SAP Identifier	MRXBOXAB-ECO-LP2		
Application	Specific Fan Power (W/l/s)	Heat Exchange Efficiency	Energy Saving Trust Best Practice Compliant
Kitchen + 1 Wet Room	0.48	78%	Yes
Kitchen + 2 Wet Rooms	0.61	79%	Yes
Kitchen + 3 Wet Rooms	0.77	79%	Yes

Standard Model

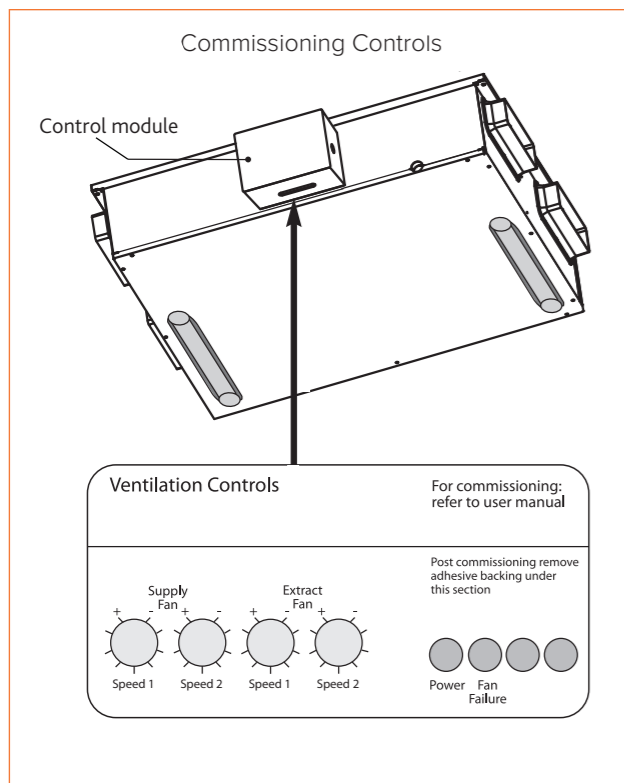

SW Model

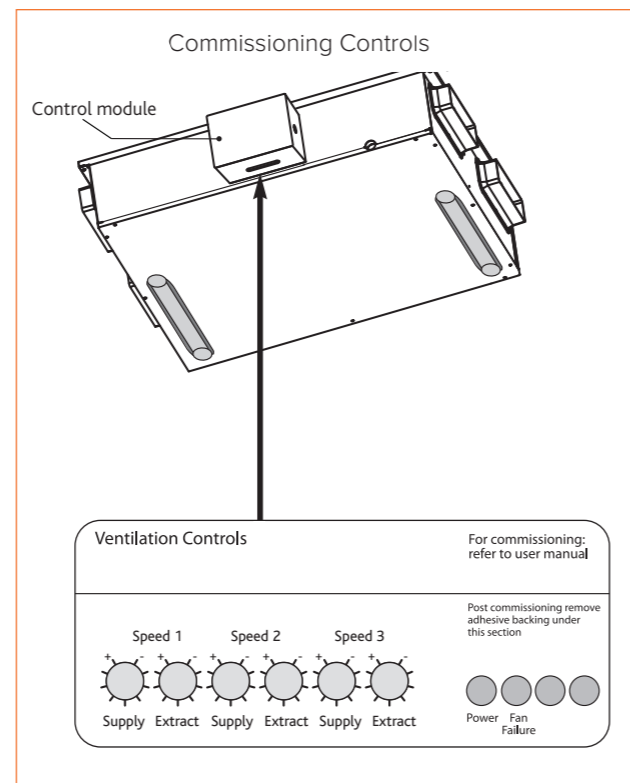

Technical – MRXBOXAB-ECO-LP2

Dimensions (mm) – Standard Unit Configuration

Weight - 37kg

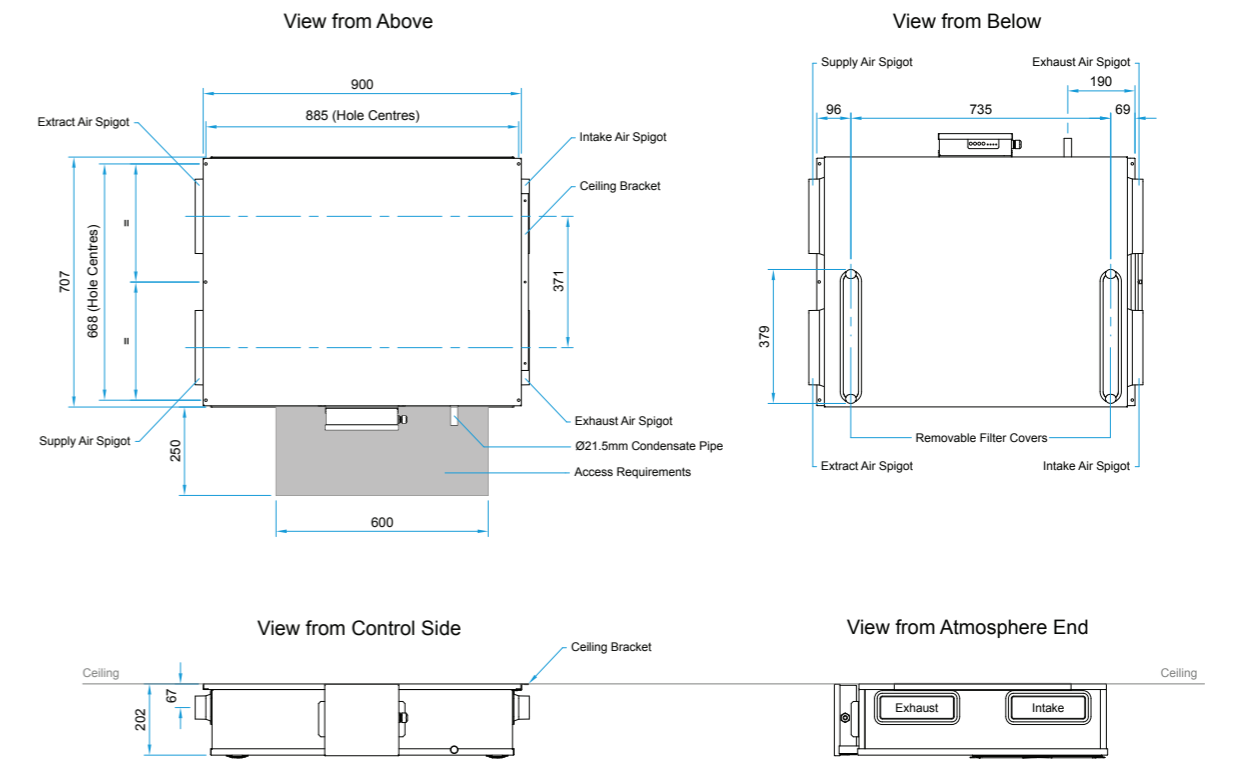

Wiring – MRXBOXAB-ECO-LP2

Unit Serving Kitchen & Bathroom

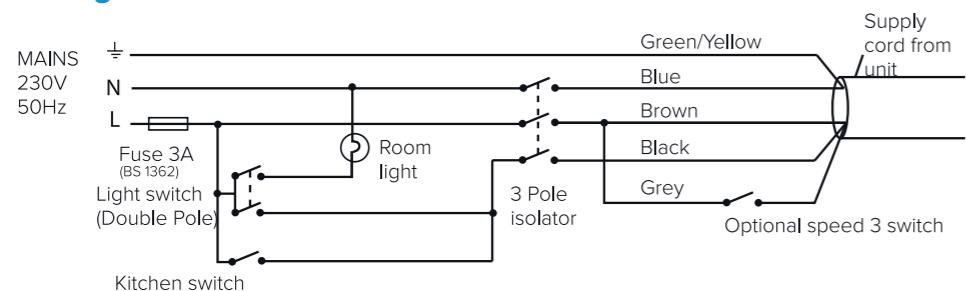

Unit Serving Kitchen & Two Bathrooms

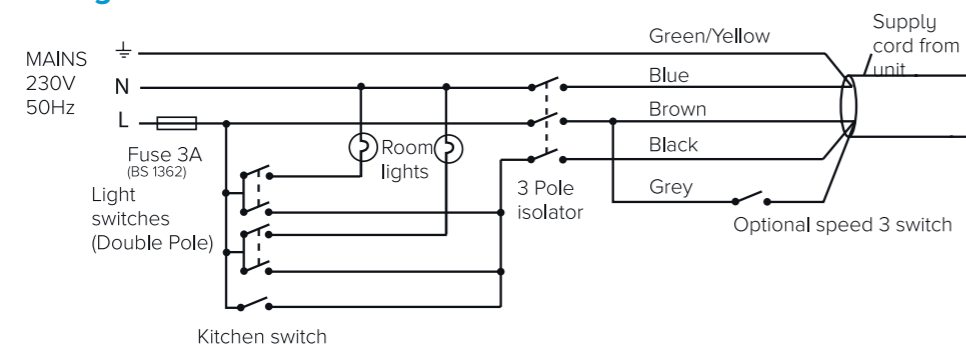

Electrical Details

Please note: the electrical connection of the unit must be carried out by a qualified electrician.

The unit is supplied with a flexible cord for connection to the mains supply. NOTE: This unit must be earthed.

The mains power supply cable should be connected to a fixed wiring installation, via a fused isolator, in accordance with current IEE wiring regulations.

Summer/Winter Switch

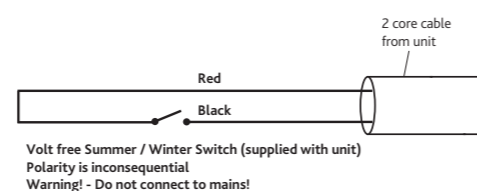

Specification

MRXBOXAB-ECO-LP2

SPECIFICATION

The unit shall be manufactured from galvanised sheet steel with a white, pre-painted removable access panel. The unit shall be fully insulated providing excellent thermal and acoustic characteristics and shall be complete with a multi-plate, aluminium, counter-flow, high-efficiency heat exchanger block, with a thermal efficiency of up to 80%. The heat exchanger shall be protected by ISO Coarse filters on fresh air inlet and system extract. The heat exchanger and filters shall be accessible via the underside access panels, enabling quick and easy maintenance.

The unit shall have a maximum depth of 200mm to fit within ceiling void restrictions. The unit shall have low energy, high-efficiency EC fan/motor assemblies with sealed for life bearings, the impellers shall be backward curved centrifugal type. The motors shall be suitable for an ambient temperature of 40°C.

Motor assemblies shall be removable from the underside of the unit and will not require the unit to be removed from situ.

The unit shall be supplied complete with a condensate drip tray and 21.5mm drain connection.

The unit shall be suitable for 204x60mm rectangular ducting. Note: The unit is also available in Opposite Handed format, refer to spigot configuration for set up.

The breakout noise level and power requirements shall be as detailed by the unit manufacturer and in accordance with the ventilation equipment schedule.

Units shall be MRXBOXAB-ECO-LP2 and MRXBOXAB-ECO-LP2-OH as manufactured by Nuair and shall be listed on the PCDB database.

OPERATION FOR TWO SPEED (STANDARD MODEL)

The supply and extract ventilation unit shall be positioned as indicated on the drawings and shall be in accordance with the particular fan schedule in the specification.

The combined supply and extract with heat recovery unit shall supply filtered fresh air to each of the habitable rooms and moisture-laden air shall be extracted from the wet areas e.g. bathroom, en-suite, w.c, kitchen, utility rooms, etc. The supply air shall be pre-heated by the warm extract air via the integrated counter-flow heat exchanger element. The extracted air shall also be filtered before it reaches the heat exchanger block. The ventilation unit shall vary its speed and, therefore, the ventilation rate, as it receives signals from one of the following:

- Switched live signal from light/remote switches/remote switch/humidistat switch.

The unit shall have the facility to commission the supply and extract fans independently on minimum speed (continuous background ventilation) and boost speed via inbuilt minimum and maximum speed adjustment. The fans shall have infinitely variable speed control.

INTEGRAL AUTOMATIC SUMMER BYPASS

Including Automatic Summer Bypass where intake and return air temperatures shall be measured so that supply air temperatures can be maximised during winter months and minimised as external ambient temperature rises. The Summer bypass damper shall be opened by a wax actuator. Supply and Extract air shall be filtered irrespective of the bypass setting (open or closed).

SUMMER/WINTER (SW) SWITCH THIRD SPEED

The unit shall feature volt-free connections for a positional switch controlling the bypass logic profile. Summer setting shall target under 20 degrees C internal dwelling temperature. Winter setting shall ensure heat recovery at all times. Temperature control logic shall be factory pre-set and require no on-site programming. The unit shall feature 3 commissionable speeds for both supply and extract. It shall be possible to enable the unit to its 3rd speed by means of a switch or a programmable thermostat with occupant override CM-THERM-CONTROL. The 3rd speed (overheating) shall be inhibited when outside air temperature exceeds inside temperature and bypass closes so that extracted air cools incoming fresh air.

CONTROL OPTIONS

All versions shall have the following functions integrally mounted within the fan unit on a purpose made PCB, all such components are pre-wired and factory fitted by the manufacturer:

- Independent control of background supply and extract flow rates.
- Independent control of boost speed supply and extract flow rates.
- Integral heat exchanger frost protection.
- Run/fault indication to external control systems/BMS via ES-VF.
- Integral S/L terminal for boost from remote switch, e.g. light switch.
- Additional S/L terminal for 100% boost speed from remote switch, e.g. plate switch.
- Discreet daily run monitor.
- Indication and controls – The unit shall have clear LED visual indication for maintenance, servicing and operation mode, i.e. Summer Bypass, frost protection.

The unit comes with 2 years warranty (including parts and labour).

Residential product orders or enquiries:

Tel: +44 (0)29 2085 8500
residential.enquiries@nuaire.co.uk

After sales technical support:

Tel: +44(0)29 2085 8400
aftersales@nuaire.co.uk
www.nuaire.co.uk



WESTERN INDUSTRIAL ESTATE | CAERPHILLY | CF83 1NA
T 029 2085 8200 F 029 2085 8300 E INFO@NUAIRE.CO.UK
WWW.NUAIRE.CO.UK

©Nuaire 2025-03

As part of our policy of continuous product development Nuaire reserves the right to alter specifications without prior notice.
Telephone calls may be recorded for quality and training purposes.